

Whirlpool

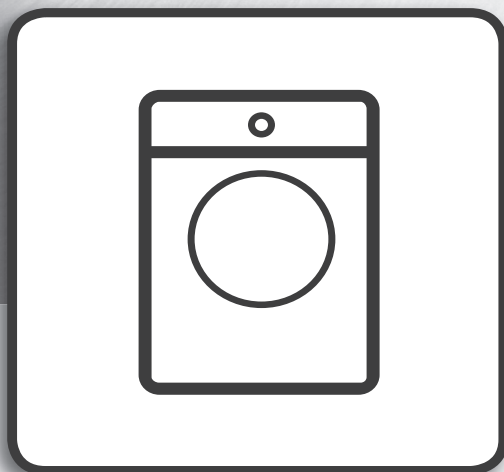

**Health & Safety, Use & Care and Installation guide**  
**產品安全指引、使用說明及安裝指南**

**Series Name 系列名稱: W Collection**

**Model 產品型號 :** 8TWFC6810LW  
8TWFC6820LW  
8TWFC6820LC



[www.whirlpool.com.tw](http://www.whirlpool.com.tw)

## 目錄

|                |    |
|----------------|----|
| 產品規格 .....     | 3  |
| 洗衣機安全 .....    | 4  |
| 放入洗衣用品 .....   | 6  |
| 洗衣機維護與保養 ..... | 7  |
| 安裝說明 .....     | 10 |
| 安裝需求 .....     | 11 |
| 工具和零件 .....    | 11 |
| 地點要求 .....     | 12 |
| 排水系統 .....     | 12 |
| 電氣要求 .....     | 13 |
| 安裝說明 .....     | 14 |
| 連接排水管 .....    | 14 |
| 連接進水管 .....    | 14 |
| 平放洗衣機 .....    | 15 |
| 完成安裝檢核清單 ..... | 16 |
| 行程指南 .....     | 17 |
| 故障排除 .....     | 23 |

## TABLE OF CONTENTS

|  |    |
|--|----|
| PRODUCT SPECIFICATIONS.....                        | 33 |
| ALL-IN-ONE WASHER DRYER SAFETY .....               | 34 |
| ADDING LAUNDRY PRODUCTS.....                       | 36 |
| ALL-IN-ONE WASHER DRYER MAINTENANCE AND CARE ..... | 37 |
| INSTALLATION INSTRUCTIONS.....                     | 40 |
| REQUIREMENTS .....                                 | 41 |
| Tools and Parts.....                               | 41 |
| Location Requirements .....                        | 42 |
| Drain System .....                                 | 43 |
| Electrical Requirements.....                       | 43 |
| INSTALLATION .....                                 | 44 |
| Connect Drain Hose .....                           | 44 |
| Connect Inlet Hose .....                           | 44 |
| Level All-In-One Washer Dryer .....                | 45 |
| Complete Installation Checklist .....              | 46 |
| ALL-IN-ONE WASHER DRYER CYCLE GUIDE.....           | 47 |
| TROUBLESHOOTING .....                              | 53 |



專為使用 HE 高效能洗衣劑而設計。  
Designed to use only HE  
High Efficiency detergents.

台灣惠而浦股份有限公司  
消費者免付費服務專線：0800 258 558  
消費者服務信箱：service\_tw@whirlpool.com  
官網：www.whirlpool.com.tw

Taiwan Whirlpool Corporation  
Customer Service phone number：0800 258 558  
Service Email box：service\_tw@whirlpool.com  
Official Website：www.whirlpool.com.tw

## 產品規格

| 型號                  | 8TWFC6810LW                | 8TWFC6820LW                | 8TWFC6820LC                |
|---------------------|----------------------------|----------------------------|----------------------------|
| 商品名稱                | 洗衣機                        | 洗衣機                        | 洗衣機                        |
| 適用電源                | 120 V / 60 Hz              | 120 V / 60 Hz              | 120 V / 60 Hz              |
| 最大洗衣量<br>(乾燥衣物)     | 15.0 kg                    | 17.0 kg                    | 17.0 kg                    |
| 最大乾衣量<br>(乾燥衣物)     | 10.0 kg                    | 10.0 kg                    | 10.0 kg                    |
| 適用水壓                | 0.03-0.7 MPa               | 0.03-0.7 MPa               | 0.03-0.7 MPa               |
| 額定消耗電功率             | 洗衣 1,000 W /<br>乾衣 1,200 W | 洗衣 1,000 W /<br>乾衣 1,200 W | 洗衣 1,000 W /<br>乾衣 1,200 W |
| 最高旋轉速度              | 1,200 rpm                  | 1,200 rpm                  | 1,200 rpm                  |
| 產品顏色說明 (末碼)         | W=白色                       | W=白色                       | C=暗銻色                      |
| 重量                  | 103 kg                     | 103 kg                     | 103 kg                     |
| 外觀尺寸<br>(高 x 寬 x 深) | 982 x 686 x 802 (mm)       | 982 x 686 x 802 (mm)       | 982 x 686 x 802 (mm)       |

備註：規格以實際的機身銘牌為主。

如需查詢 RoHs 資訊，請瀏覽官方網站：[www.whirlpool.com.tw](http://www.whirlpool.com.tw)。

## 您與他人的安全都非常重要。

本公司已在這份手冊與電器上提供許多重要的安全提示信息，請務必一一閱讀並遵守。



這是安全警告符號。

此符號表示存在可能導致您或他人傷亡的潛在危險。

所有安全提示信息的之前都有安全提示符號以及「危險」或「警告」字樣。分別代表：



若不立即遵照指示，您可能會面臨死亡或重傷危險。



若不遵照指示，您可能會面臨死亡或重傷危險。

所有安全提示信息都會告訴您有哪些潛在危險、如何降低受傷機率，以及不遵守指示會有哪些後果。

## 重要安全說明

**警告：**為了減少使用家用電器時發生火災、觸電或人身傷害的危險，請遵守以下基本預防措施，包含下列各項：

- 使用洗衣機之前，請詳讀所有的說明。
- 不要去洗滌或烘乾那些曾經被汽油、乾洗溶劑、易燃或容易爆炸的物質所清洗過、洗滌過、浸泡過的衣物，因為它們會釋放出可能燃燒或者爆炸的氣體。
- 不要加入汽油、乾洗溶劑或其他易燃或爆炸之物質到洗衣水裡面。這些物質的蒸汽可能會引起火災或爆炸。
- 在某些情況下，如果兩個星期以上沒有使用的熱水系統可能會產生氫氣。氫氣具爆炸性。如果熱水系統有很長一段時間未使用，在使用洗衣機之前，打開水龍頭，讓水在每個水龍頭都流出幾分鐘。這將釋放任何積聚其內的氫氣。由於氫氣易燃，不得在此期間抽菸或使用明火。
- 不要讓小孩在家用電器上或洗衣機內玩耍。當洗衣機在小孩附近使用時，請仔細照顧小孩。
- 在停止使用或棄置洗衣機前，請將洗衣機門或上蓋拆除。
- 當洗衣槽、脫水槽或洗衣棒在轉動時，請不要將手伸入洗衣機內。
- 請不要將此洗衣機安裝或存放在室外日曬雨淋之地方。
- 不得濫用控制面板。
- 請不要擅自修理或者更換任何洗衣機零件，除非您具有修理技能且明確理解本使用或維護指南或其他用戶維修說明書所指定的修理方法，否則請別擅自修理。
- 請勿使用未經製造商推薦的更換零件（例如在家中使用 3D 印表機製造的零件）。
- 請參閱《安裝說明》以瞭解接地要求和安裝方式。
- 此洗衣機的設計不適合身心障礙人士、孩童或缺乏經驗與知識的人員操作，除非已提供有關此洗衣機之使用方式的指示或在適當監督的情況下才能操作。
- 不要把沾染烹調用油的衣物放入洗衣機內。沾染烹調用油的衣物可能會引發化學反應使衣物著火。為了減少遭油污沾染衣物的起火風險，乾衣行程的最後階段不會加熱（冷卻期間）。
- 若電源線損壞時，必須由製造廠或其服務處或具有資格的人員更換以避免危險。
- 洗衣機安裝時，不得採用會限制洗衣機門完全敞開的方式安裝在可上鎖的門、滑門或轉軸位置與洗衣機轉軸位置相反的門後。
- 請務必使用隨附於洗衣機的全新水管，切勿重複使用舊水管以避免危險。
- 切勿使用可燃物質或可燃液體清潔洗衣機。
- **警告：**絕對不要在乾衣行程結束前停止洗衣機，除非迅速取出所有衣物並攤開散熱。
- 取出口袋內所有物品，例如火柴、打火機等。

請妥善保存上述安全說明

 此為「詳閱說明」符號。

## 重要安全說明

- 泡沫橡膠（乳膠泡沫）、浴帽、防水紡織品、橡膠背襯物品以及配有泡沫橡膠墊的衣服或枕頭之類的物品，不應放置在洗衣機內烘乾。
- 如果已使用工業化學藥品進行清潔，請勿使用此洗衣機。衣物中可能殘留有腐蝕性或分解性化學藥品，可能會損壞洗衣機並產生有害煙霧。
- 請勿讓棉絮堆積在橡膠圈或內側滾筒上。
- 請勿在洗衣機中烘乾未經清洗的衣物。
- 沾有烹調用油、丙酮、酒精、汽油、煤油、去污劑、松節油、蠟和除蠟劑等物質的衣物，應先在熱水中用適量的清潔劑洗滌，才能放進洗衣機烘乾。請按照衣物柔軟劑說明中來使用衣物柔軟劑或類似產品。
- 乾衣行程的最後階段不會加熱（冷卻行程），讓衣物在不致受損的溫度下放置在洗衣機內。
- 洗衣機必須連接至 0.03-0.7 MPa 的水壓。
- 本洗衣機適合家庭和類似用途，例如：商店、辦公室，或其他工作環境的員工用餐區域；農舍；飯店、汽車旅館和其他住家類型環境的顧客；民宿類型環境；大樓、公寓或自助式洗衣店內商用區域。
- 底部開口不得被地毯遮擋。
- **警告：**不得透過外部開關裝置（例如計時器）為洗衣機供電，也不能將其連接到由公用事業公司定期打開和關閉的電路上。

請妥善保存上述安全說明

 此為「詳閱說明」符號。

 **警告**



**觸電危險**

- 將插頭插入一個三孔的接地電源插座上。
- 請勿拔掉接地插腳。
- 請勿使用轉接頭。
- 請勿使用延長線。
- 違反這些指示可能導致人員傷亡、失火或觸電。

 **警告**

**過重危險**

- 請動用兩名或多名人員搬運與安裝洗衣機。
- 否則可能導致人員後背或其他部位受傷。

## 放入洗衣用品

### 將 HE 高效能洗衣劑放入籃內：

裝入衣物前可將洗衣膠囊、Oxi 類型加強清潔劑、護色漂白劑或香味晶球放入內桶。使用單次劑量洗衣膠囊時，確保已停用 Load & Go™ 洗劑智慧投放盒。

**備註：**請遵循製造商的說明，決定洗衣用品的用量。

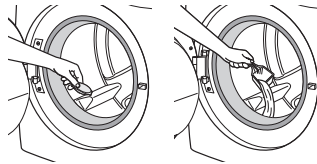

### 將液態含氯漂白劑注入單次衣物洗劑盒內：

將液態含氯漂白劑加進漂白劑投放格內（若需要）。不得過量添加、稀釋或使用超過 2/3 杯 (165 mL)。使用液態含氯漂白劑的行程內，不得使用護色漂白劑或氧系漂白劑。

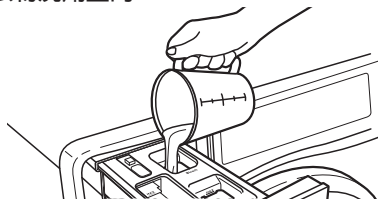

### 重要事項：

- 務必測量液態含氯漂白劑。利用有傾倒口的量杯計算，請勿透過猜測決定用量。
- 不得注入超過格子內顯示的「Max」線。溢出液體可能會損壞衣物。
- 使用「槽洗淨®」行程期間，不得使用增稠、易倒或不噴濺的漂白劑，因為此舉會產生過多泡沫。
- 不得將液態含氯漂白劑加至洗劑智慧投放盒內。
- 慢慢關上洗劑盒。請確保洗劑盒已關緊。

### 可將衣物柔軟劑放進單次衣物洗劑盒內：

倒入定量的衣物柔軟劑至衣物柔軟劑投放格內。請務必遵循製造商的說明，根據您的衣物量，使用正確的柔軟劑用量。衣物柔軟劑一律會在最後一次洗滌時加入。

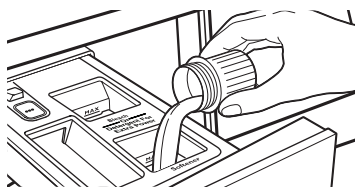

**重要事項：**不得過量添加、稀釋或使用超過製造商建議的柔軟劑用量。倒入柔軟劑時，不得超過格子內顯示的「Max」線。過量的柔軟劑將立即進入機器內。

- 不得將柔軟劑溢出或滴落至衣物上。
- 不得在本機器內使用衣物柔軟劑輸送球。這類型洗劑無法被正確投放。
- 不得使用衣物柔軟紙，因它可能會讓衣物染色。

### 添加 HE 高效能洗衣劑至 Load & Go™ 洗劑盒：

僅可使用 HE 高效能洗衣劑。視洗劑盒，或是否足以清洗多批衣物而定，洗劑智慧投放盒能放置 67.6 oz (2 公升) 的 HE 高效能洗衣劑。

### 注滿洗劑智慧投放盒：

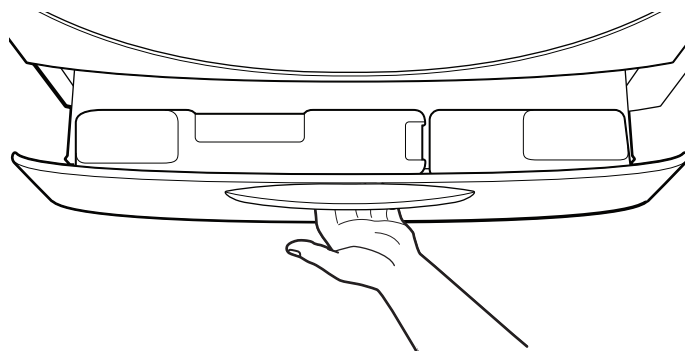

拉開機器底部的把手，打開洗劑盒。可視需求從機器取下整個洗劑盒。找到 Load & Go™ 洗劑智慧投放盒。輕輕向上拉出位於洗劑智慧投放盒蓋上的突出物，抬起注液門。



添加 HE 高效能洗衣劑至「Max」線（參閱右方的插圖）。關上注液門。關門後會發出喀嗒聲。確定濃度設定正確。（參閱「行程指南」）

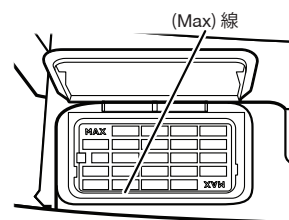

當您再加入洗劑、更換洗衣精類型或濃度，或長期不使用洗衣機時，請沖洗 Load & Go™ 容器。欲知清潔洗劑的說明，參閱「洗衣機保養」部份。

當您希望機器使用 Load & Go 洗劑智慧投放盒進行自動洗劑投放時，請確保已啟用 Load & Go™ 洗劑智慧投放盒選項。另外，請勿將任何洗劑添加至單次衣物洗劑盒。

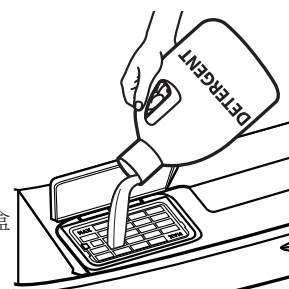

### 添加 HE 高效能洗衣劑至單次衣物洗劑盒：

直接將適量的 HE 高效能洗衣劑加入至洗衣精放置格內。若為洗衣粉，將選擇器升高至高位。若為洗衣劑，將選擇器推下至低位。不要過度注入洗劑；添加太多洗衣劑可能讓它太早分配至洗衣機。使用單次劑量洗劑投放盒時，確保已停用 Load & Go™ 洗劑智慧投放盒。



### 充分運用您的洗衣機：

您的新機器出廠時預設執行「洗衣」行程。您也可以選擇執行「洗衣 & 烘衣」或「單獨烘衣」行程。

為達成最佳烘衣效果並避免衣物起皺，請勿放入超過一半的衣物。由於這部機器採用無排氣式乾衣技術，與排氣式洗衣機相比之下，會需要較長的乾衣時間。

# 洗衣機維護與保養

## 進水管

使用洗衣機五年後請更換進水管，以降低水管損壞的風險。若發現突起物、糾結、割痕、磨損或漏水，定期檢查和更換進水管。

更換進水管時：

用不褪色馬克筆在標籤上標記更換日期。

檢查進水管上的老舊橡膠封條有沒有堵塞在機器的進水閘上。

新洗衣機應連接新進水管，確保妥善的密封。

## 洗衣機保養

### 維持機器清潔和最佳效能的建議

1. 請務必使用高效能洗衣劑並遵循 HE 高效能洗衣劑製造商對 HE 高效能洗衣劑用量的說明。切勿使用超過的建議用量，因為此舉可能增加洗衣劑和污垢殘留積聚在機器的速率，進而產生異味。
2. 偶爾要用溫水或熱水洗衣（不僅是只用冷水洗衣），因為溫水或熱水更能控制污垢和洗衣劑積聚的速率。
3. 機器使用後略為開啟機門，有助於風乾洗衣機、避免能發出異味的殘留物積聚。
4. 定期清除機門窗戶整個內部表面的殘留物。若可以的話請用濕布擦拭機門的整個內部。

### 清潔您的洗衣機

展開下方建議的例行清潔流程前，閱讀完整的說明。應最少每月執行本機器維護程序一次，或 30 次行程後，須視何者先發生而定。此舉能控制污垢和洗衣精積聚在機器內的速率。請注意，由於這是一台不具棉絮篩網的洗衣機，因此與一般洗衣機相比，您可能會在門膠圈上看到更多的棉絮堆積。

### 清潔門膠圈

1. 打開機器門，取出所有衣物。
2. 檢查機門開口的灰色門膠圈以及洗衣筒是否有污漬、積聚污垢或棉絮。拉開門膠圈，檢查門膠圈下方所有區域，並檢查是否有異物或棉絮。
3. 若找到污漬、積聚污垢或棉絮之處，用下列程序之一，擦拭門膠圈區域：
  - a. Affresh® 機器清潔拭紙程序：
    - i. 完成行程後，輕輕拉回橡膠的門膠圈，並用 affresh® 機器清潔拭紙有紋路的一面清潔整個表面。
  - b. 稀釋液態含氯漂白劑程序：
    - i. 混合稀釋的漂白劑：用 3/4 杯 (177 mL) 液態含氯漂白劑和 1 加侖 (3.8 公升) 的溫熱自來水。
    - ii. 用沾有稀釋溶劑的濕布擦拭門膠圈區域。
    - iii. 靜置 5 分鐘。
    - iv. 用乾布徹底清潔所有區域，並打開機門，風乾機器內部。

### 重要事項：

- 用漂白水清潔時要佩戴手套。
- 參考漂白水製造商的說明，正確使用產品。

### 清潔洗衣機內部

本機器配備特殊行程，能結合「affresh® 槽洗錠」或一般的液態含氯漂白劑，徹底清潔機器的內部。蒸氣機種也利用蒸氣，提升此特殊行程中的清潔力。

**重要事項：**使用「槽洗淨®」行程期間，不得使用增稠、易倒或不噴濺的漂白劑，因為此舉會產生過多泡沫。

**備註：**展開清潔流程前，請閱讀完整的說明。

### 開始程序

1. 「槽洗淨®」（建議使用，因其能達成最佳效能）：
  - a. 打開機門並取出所有衣物。
  - b. 使用「affresh® 機器清潔拭紙」或柔軟的濕布或海綿，擦拭機門窗戶。
  - c. 放入「affresh® 槽洗錠」至機器滾筒內。
  - d. 不得將「affresh® 槽洗錠」加至洗劑盒內。
  - e. 遵行本程序時，不得放入任何洗衣精或其他化學物至機器內。
  - f. 關閉機門。
  - g. 選擇「槽洗淨®」行程。
  - h. 選擇「冷風清新®」選項，有助於完成行程後風乾機器內部。

**備註：**機器將儲存您上次的選項選擇，且在未來的洗衣行程中繼續使用，直到您取消選擇該選項。

  - i. 觸碰並按住「啟動/暫停」，開始行程。「槽洗淨®」行程說明如下。
2. 含氯漂白劑程序：
  - a. 打開機門並取出所有衣物。
  - b. 打開單次衣物洗劑盒，放入常用的含氯漂白劑至漂白劑放置格和衣物柔軟劑放置格的「MAX」線。可使用傳統或 HE 含氯漂白劑。

**重要事項：**不得使用增稠、易倒或不噴濺的漂白劑，因為會產生過多泡沫。

**備註：**使用比建議量更多的液態含氯漂白劑長期下來將損壞機器。

  - a. 關閉機門和洗劑盒。
  - b. 遵行本程序時，不得加入任何洗衣精或其他化學物至機器內。
  - c. 選擇「槽洗淨®」行程。
  - d. 選擇「冷風清新®」選項，有助於完成行程後風乾機器內部。

**備註：**機器將儲存您上次的選項選擇，且在未來的洗衣行程中繼續使用，直到您取消選擇該選項。

  - a. 觸碰並按住「啟動/暫停」，開始行程。「槽洗淨®」行程說明如下。

**備註：**為取得最佳成果，請勿中斷行程。

## 「槽洗淨®」行程的運行說明：

1. 「槽洗淨®」行程自動偵測洗衣機內是否有任何衣物。
2. 若未偵測到衣物，將開始行程。
  - a. 若偵測到任何衣物，將顯示「rL」（取出衣物）。機門將解鎖。打開機門並取出洗衣筒內的所有衣物。
  - b. 觸碰「電源」，清除「rL」代碼。
  - c. 觸碰並按住「啟動/暫停」，重新開始洗衣行程。
3. 僅蒸氣機種：在行程的前 20 分鐘，洗衣機將啟動蒸氣，但滾筒不會轉動或注水。在此初步階段您將看到機門窗戶上凝結的水滴。若您正在使用「affresh® 槽洗錠」，它在蒸氣階段不會全部溶解。這是正常現象。
4. 行程完成後，略為打開機門，讓空氣流通得更好，並風乾洗衣機內部。

## 清潔洗劑盒

使用「槽洗淨®」行程一段時間後，您可能發現機器洗劑盒積聚殘留物。

欲清除洗劑盒的殘留物，取出洗劑盒並用「affresh® 機器清潔拭紙」或濕布擦拭表面，並於運行「槽洗淨®」行程之前或之後，用毛巾擦乾盒子。若有需要，使用全效表面清潔劑。

欲清除 Load & Go™ 洗劑智慧投放盒的殘留物，拉起洗劑盒的把手，並從洗衣機櫥櫃中將它拉出，然後用流水徹底沖洗。用「affresh® 機器清潔拭紙」或濕布擦拭洗劑盒的表面，再用毛巾擦乾盒子。若有需要，使用全效表面清潔劑。

把洗劑盒放回機器櫥櫃，確保其已穩妥就定位。

**備註：**不得用洗碗機清潔洗劑盒。

## 清潔洗衣機外部

使用「affresh® 機器清潔拭紙」或柔軟的濕布或海綿，擦拭任何溢出物。偶爾擦拭機器外部，讓它看起來光潔如新。使用「affresh® 機器清潔拭紙」或溫和的肥皂和水。

**重要事項：**為避免損壞洗衣機的烤漆，不得使用磨蝕性產品。

## 槽洗淨行程提醒

**備註：**並非所有「槽洗淨®」行程都帶有提醒燈。

機器運行 30 個洗衣行程後，洗衣行程結束後「槽洗淨®」的 LED 燈將閃爍。這是提醒您需運行「槽洗淨®」行程。

若未執行「槽洗淨®」行程，在完成 3 次正常洗衣行程後，LED 燈會在洗衣行程結束時停止閃爍。完成 30 次以上的洗衣行程後，「affresh® 槽洗淨」LED 燈將於特定洗衣行程結束後再度閃爍，作為提醒。

## 取出洗劑盒

### 單次衣物洗劑盒

#### 拆卸方式：

1. 拉出洗劑盒，直到不能把它拉出為止。
2. 按下釋放鍵，並把它拉出，以取出洗劑盒。

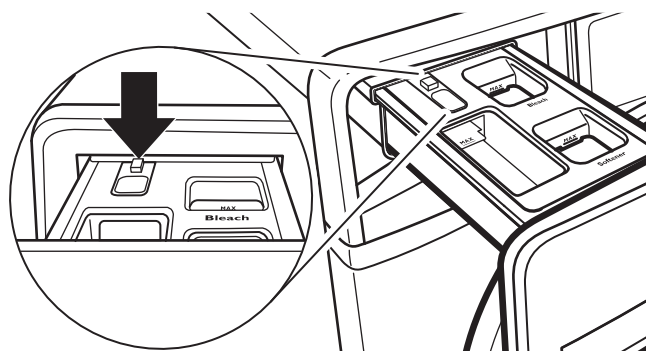

3. 直接向上拉起蓋子面板。

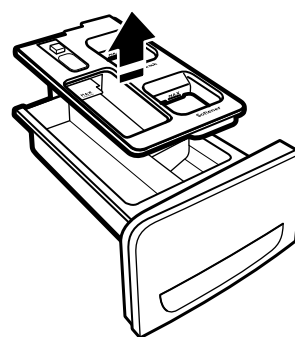

#### 更換方式：

1. 把蓋板放回洗劑盒的撐柱上。輕壓蓋板，使其穩妥就定位。
2. 將洗劑盒的邊緣對齊滑道，接著把洗劑盒滑進槽內。

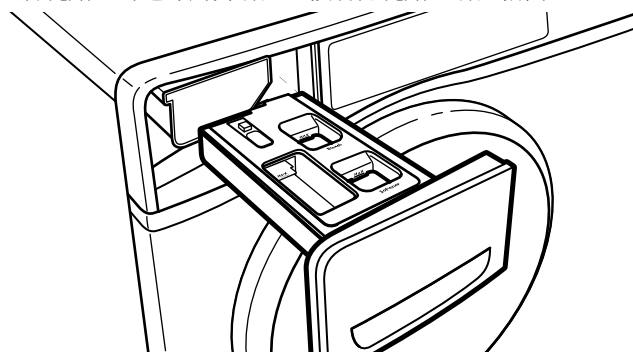

## 清潔 Load & Go™ 容器

當您再加入洗劑、更換洗衣精類型或濃度，或長期不使用洗衣機時，請沖洗 Load & Go™ 容器。

1. 將洗劑盒向外拉出到底。
2. 拉出 Load & Go™ 容器。



3. 拉起注入蓋，用溫水徹底沖洗它。

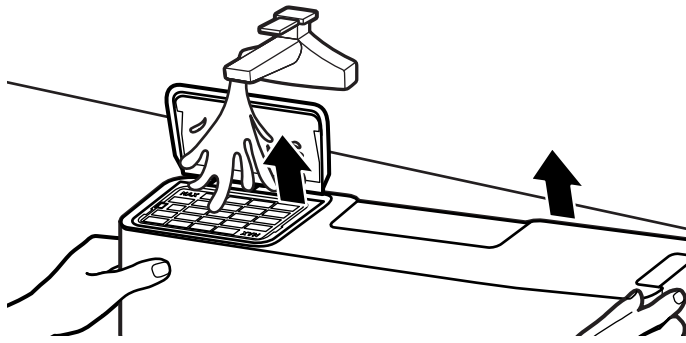

4. 最後放著風乾。

### 不再使用和度假保養

只可在您在家時運行機器。若搬家，或將有一段時間不使用洗衣機，遵循下列步驟：

1. 拔下機器電源，或切斷電源。
2. 關閉機器水源，避免因水壓升高導致淹水。  
**實用秘訣：**在機器上標記提醒備註，下次使用洗衣機前要恢復供水。
3. 清潔洗劑盒請參閱「清潔洗劑盒」。

### 冬季儲存保養

**重要事項：**為避免毀損，請將機器安裝並存放在不會結冰的地方。由於管內可能殘存水份，水結冰後可能會損壞機器。若在寒冷天氣下存放或搬運機器，請做好防凍措施。

#### 機器的防凍措施：

1. 關閉冷熱水龍頭；接著拆下進水管並進行排水。  
**實用秘訣：**在機器上標記提醒備註，下次使用洗衣機前要恢復供水。
2. 放 1 quart (1 公升) 的 R.V. 防凍劑至機器滾筒內，以「標準」行程運行機器約 2 分鐘，混合防凍劑和殘留水份。
3. 拔下洗衣機的插頭，或切斷電源。

### 運送洗衣機

1. 關閉兩個水龍頭。拆下和排乾進水管。
2. 若需在寒冷的天氣下搬運機器，執行作業前請遵循「冬季儲存保養」說明。
3. 從排水系統和機器背面拆下排水管。
4. 拔下電源線插頭。
5. 把進水管和排水管放在機器滾筒內。
6. 用橡皮筋或纜線紮帶紮緊電線，避免它們懸吊至地面。  
**重要事項：**致電維修部安裝全新的運送螺栓。不得重複使用運送螺栓。必須以直立的方式搬運機器。為避免機器的結構毀損，搬遷和設定洗衣機的作業，必須由認證技工妥善執行。

## 警告



### 觸電危險

- 將插頭插入一個三孔的接地電源插座上。
- 請勿拔掉接地插腳。
- 請勿使用轉接頭。
- 請勿使用延長線。
- 違反這些指示可能導致人員傷亡、失火或觸電。

### 重新安裝/再次使用

在長期未用、度假、冬季儲存或搬遷後重新安裝機器：

1. 參閱「安裝說明」，尋找洗衣機的安裝位置、平放和連接機器。
2. 再次使用機器前，請遵行建議程序來運行機器：

#### 再次使用洗衣機：

1. 沖洗進水管。重新連接進水管。開啟冷熱水水龍頭。
2. 插上機器插頭，或重新連接電源。
3. 用「強力洗滌」行程運行機器，以清潔機器及清除防凍劑。僅使用 HE 洗衣精，使用廠商建議中量衣物所用劑量的一半

### 清潔排水幫浦過濾器/排出殘留水份

備註：偶爾執行下列程序。

**重要事項：**清潔排水幫浦過濾器之前，請務必關閉機器電源。

1. 拉開機器底部的把手，打開洗劑盒。您將看到排水幫浦過濾器。鬆開兩邊的釋放鍵，取出洗劑盒。用手指向下推進洗劑盒右邊的釋放鍵，以及洗劑盒左上的釋放鍵。

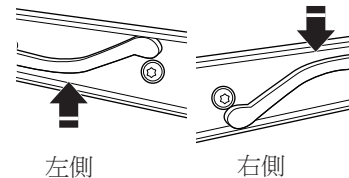

左側

右側

- 放一個平寬的容器在排水幫浦過濾器下方，收集排水。鬆開管夾的黑色管子，取下插頭並排出管內水份至容器。倒空容器內的水份。若有必要，重複此程序，直到排除所有水份。確定黑色管子已完全乾燥，裝回插頭並連接管子和夾子。

**備註：**若無法妥善排水，稍微推進管子，清除任何可能的扭曲處。

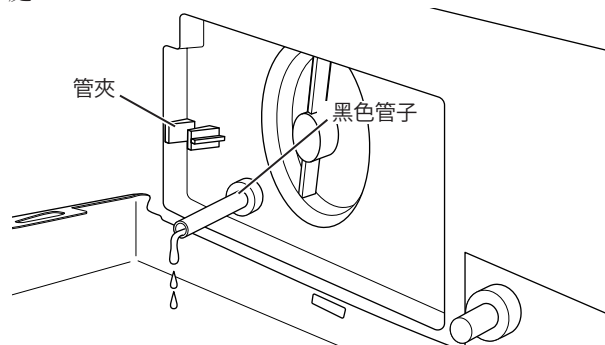

- 放一塊棉布在排水幫浦過濾器下方，吸收任何仍在其內的水份。接著逆時針方向轉動排水幫浦過濾器，以便把它取下。

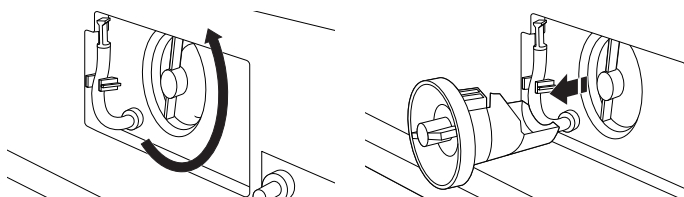

- 每個月檢查一次排水幫浦過濾器。用手從過濾器取出大堆棉絮，並把棉絮放在適當的廢棄物容器內。用水沖洗並清除過濾器內其餘的殘留物。

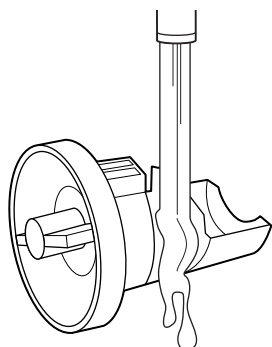

- 順時針方向旋轉排水幫浦過濾器，重新把它接上。確定拴緊它，而過濾器把手盡量處於垂直位置。

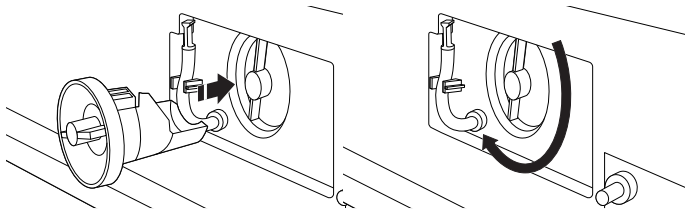

- 裝回並關上洗劑盒。裝回洗劑盒時，確定已同步插入至兩條軌道。您將聽到喀嗒聲，說明已妥善插入至兩條軌道。為確保正確擺放洗劑盒，完全把它拉出。洗劑盒應能全部拉出，惟仍被軌道鎖住。確定排水管已連接管夾，且處於切口下方。

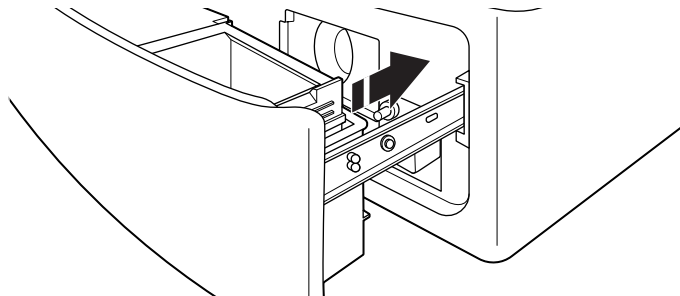

### 更多清潔作業

輕輕拉開橡膠的機門膠圈，並用「affresh® 機器清潔拭紙」有紋路的一面清潔任何有污漬、積聚污垢或棉絮之處。

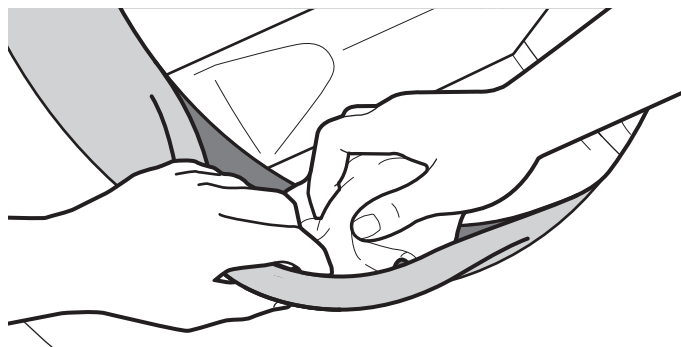

### 警告

#### 過重危險

請動用兩名或多名人員搬運與安裝洗衣機。  
否則可能導致人員後背或其他部位受傷。

### 安裝說明

**備註：**為了避免地面損毀，請在移動機器之前將它放在硬紙板上。

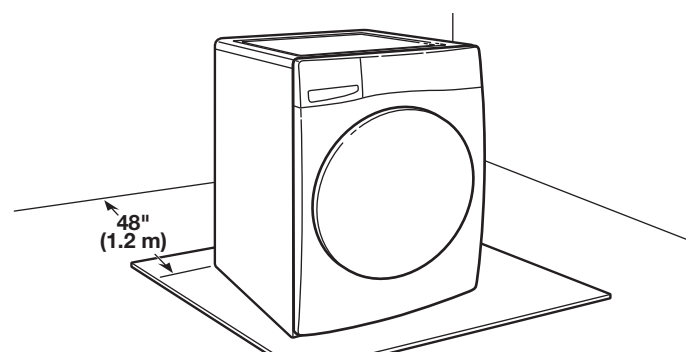

### 移動洗衣機

必須拆除所有運輸材料以確保正確操作並避免機器產生過多噪音。將機器移到最終位置的 4 英尺（1.2 公尺）範圍內。它必須處於完全直立的位置。

## 找出運送螺栓

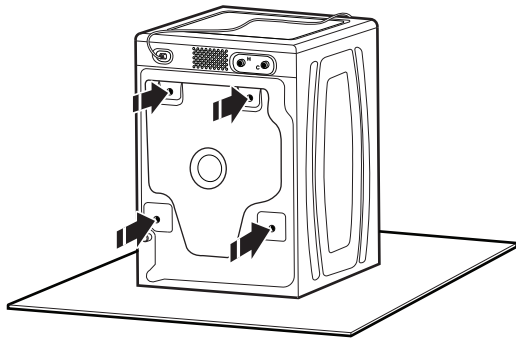

在機器背面找出四顆運送螺栓。

## 取下洗衣機的運送螺栓

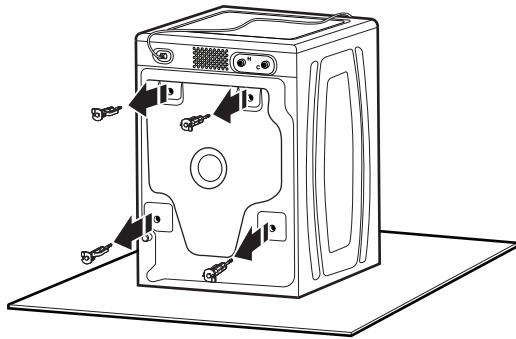

使用 5/8" (16 mm) 板手鬆開螺栓。

沿箭頭方向拉出機器上的每個螺栓，然後從機器背面拉出螺栓和塑膠墊片。丟棄螺栓和墊片。

**備註：**在完成安裝之前，請勿插入機器電源。

## 安裝需求

### 工具和零件

#### 工具和零件



活動或開口扳手 1/2" (13 mm)、5/8" (16 mm) 和 9/16" (14 mm)

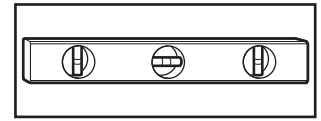

水平儀

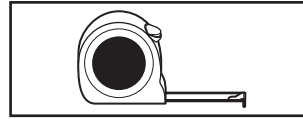

直尺或捲尺

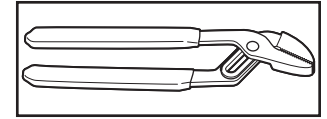

可打開至 1 9/16" (39.5 mm) 的鉗子

#### 選用工具

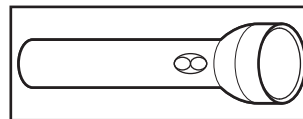

手電筒

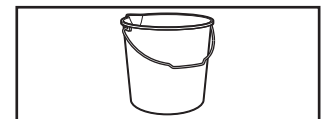

水桶

#### 機器隨附配件

**備註：**所有安裝所需隨附配件均在機器桶中。

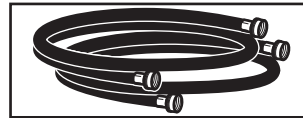

進水管 (2)

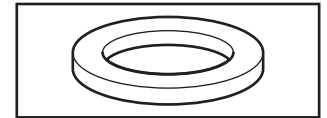

扁平水管墊圈 (4)

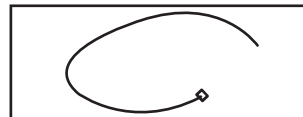

繫線帶



帶夾子和管頭的排水管 (可能以未組裝形式出貨)

#### 可用配件：

您的機器有搭配底座可供選購。請聯繫您的零售商以獲取訂購資訊，或參閱《快速入門指南》中的「協助或服務」。

#### 替代零件 (未隨附於機器)：

安裝可能需要額外零件。如需訂購，請撥打《快速入門指南》上的免付費電話。

#### 若您有：

高架汙水管

#### 您將需要：

標準 20 加侖 (76 公升) 高 39" (990 mm) 的排水槽或公用水槽，污水泵和連接器 (可向當地供應商購買)

## 地點要求

正確的安裝是您的責任。

您將需要：

- 一個熱水器並設為 120°F (49°C)。
- 一個接地電源插座，位於洗衣機背面 6 英尺 (1.8 公尺) 電源線範圍內。
- 冷熱水龍頭，位於機器 4 英尺 (1.2 公尺) 熱水和冷水注入閥範圍內，水壓為 0.03-0.7 MPa。
- 平整地面，整台機器下的坡度最多為 1" (25 mm)。不建議將其安裝在地毯上或帶有泡棉襯裡的表面上。
- 地板必須能夠支撐 315 磅 (143 公斤) 的機器總重量 (水和衣物)。

**重要事項：**請勿在露天位置或溫度低於 32°F (0°C) 的地方安裝、儲存或操作機器。使用後殘留在機器內的水份可能會在低溫下造成損毀。請參閱「洗衣機保養」以瞭解防凍措施資訊。

## Whirlpool® 機種\*

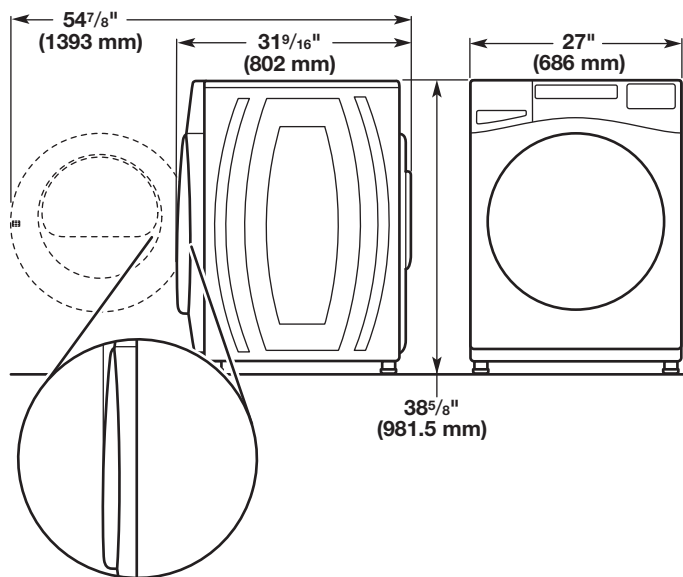

\*欲知您的機種更多詳情 (或資訊)，請參閱官網所列出的「規格表」，網址為：[www.whirlpool.com.tw](http://www.whirlpool.com.tw)。

自訂櫥櫃下安裝：

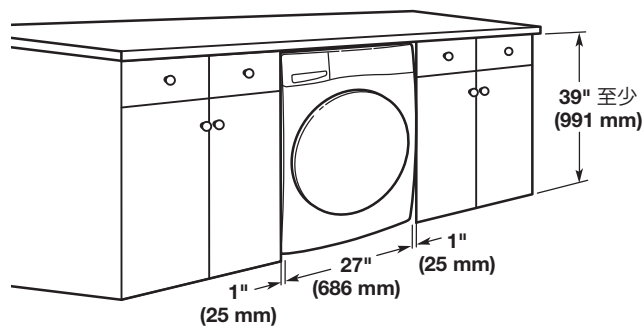

嵌入式或壁櫥安裝：

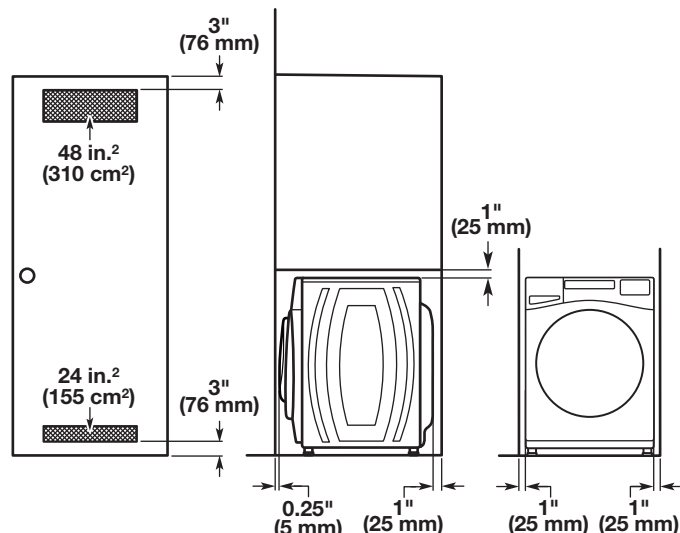

自訂櫥櫃安裝：

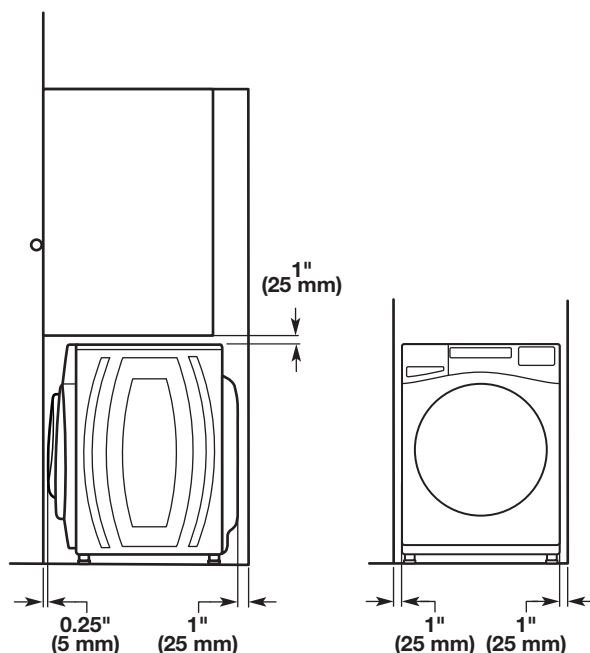

## 排水系統

可以使用地面排水管、牆立管或地面立管或洗衣盆安裝排水系統。選擇所需方法。

**重要事項：**為避免虹吸現象，置於立管內部或水槽頂部下方的水管不應超過 4.5" (114 mm)。用紮線帶將排水管固定。

地面立管排水系統

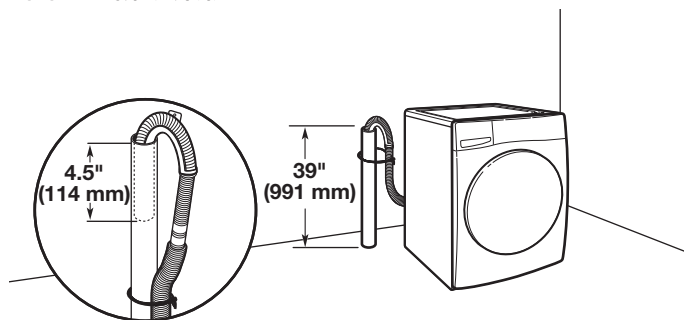

立管排水管的最小直徑：2" (51 mm)。最低排水量每分鐘 17 加侖 (64 公升)。提供 1/4" (6 mm) 直徑至 1" (25 mm) 直徑的立管連接器可供選購 零件料號 3363920)。立管頂部必須離地至少 39" (991 mm)；安裝高度不能超過距離機器底部 96" (2.44 m)。如果您有高架污水管且必須將水抽送到 96" (2.44 m) 以上的高度，則需要一個排水幫浦和相關的硬體。請參閱「替代零件」。

### 牆立管排水系統

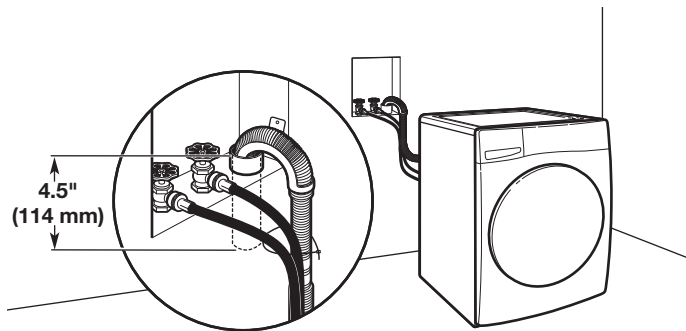

請參閱「地面立管水系統」要求。

### 洗衣盆排水系統

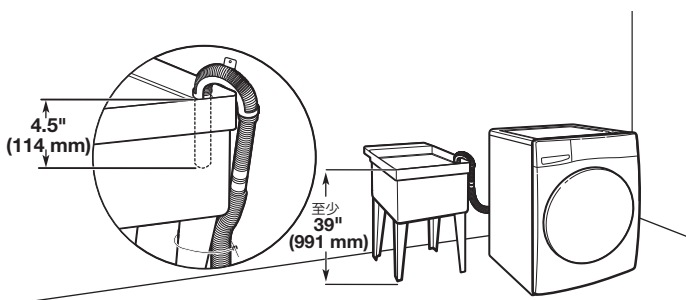

最少排水容量：20 加侖 (76 公升)。洗衣盆頂部高度必須高於地面至少 39" (991 mm)；安裝高度不能超過距離機器底部 96" (2.44 m)。

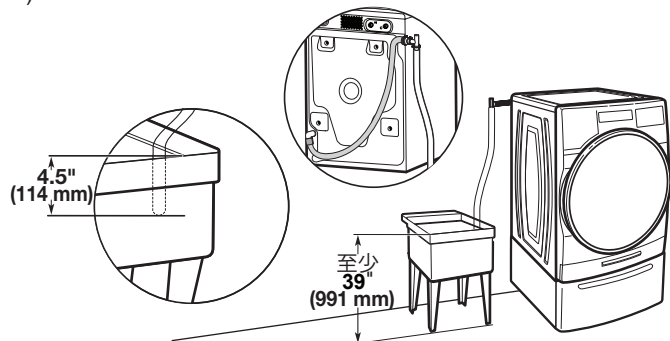

### 地面排水系統

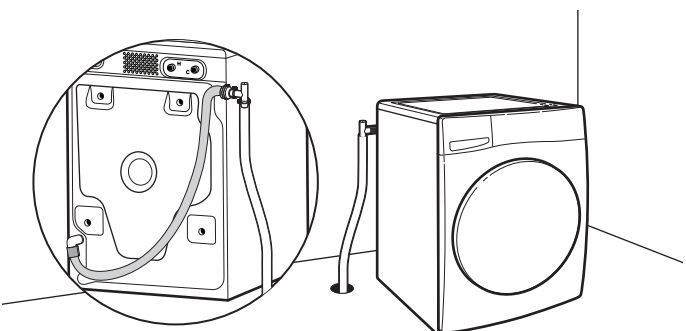

地面排水系統需要一個虹吸截斷套件、2 個連接器套件和一條可以個別購買的延長排水管。請聯絡經銷商以取得訂購資訊，或參閱《使用入門說明》的「協助或服務」。最低虹吸截斷高度：從機器底部起算 28" (710 mm)。(可能需要額外軟管。)

## 電氣要求

**警告**



### 觸電危險

將插頭插入一個三孔的接地電源插座上。  
請勿拔掉接地插腳。  
請勿使用轉接頭。  
請勿使用延長線。  
違反這些指示可能導致人員傷亡、失火或觸電。

- 要求 120V、60Hz、純交流電、15 A 或 20 A 帶保險絲的電源。建議使用延時保險絲或斷路器。建議提供僅用於此設備的個別斷路器。
- 本機器配有一條含三孔接地插頭的電源線。
- 為了將可能的觸電危險減到最低，必須將電源線插入相符的三孔接地型插座，並依照當地法規和條例進行接地。若沒有相符插座，客戶有責任和義務讓合格的電工安裝正確接地的插座。
- 若法規許可且已用獨立接地電線，建議您請合格電工確認是否已預留足夠的接地路徑。
- 請勿接地至瓦斯管。
- 若您不確定機器是否正確接地，請諮詢合格的電工。
- 不要在中性或接地電路上接入保險絲。

### 接地說明

#### 對於接地、電源線連接的洗衣機：

本洗衣機必須進行接地。在發生故障的情況下，接地可以透過提供電流阻力最小的路徑來降低觸電風險。本洗衣機配有一條設備接地線和接地插頭的電源線。必須將插頭插入適當的插座，並依照所有當地法規和條例進行正確的安裝和接地。

**警告：**不當連接設備接地線可能會導致觸電危險。若您不確定設備是否正確接地，請諮詢合格的電工或檢修人員。請勿修改設備隨附的插頭 - 若插頭不適用於插座，請讓合格的電工安裝合適的插座。

請妥善保存上述安全說明

# 安裝說明

## 連接排水管

### 將排水管連接到排水口

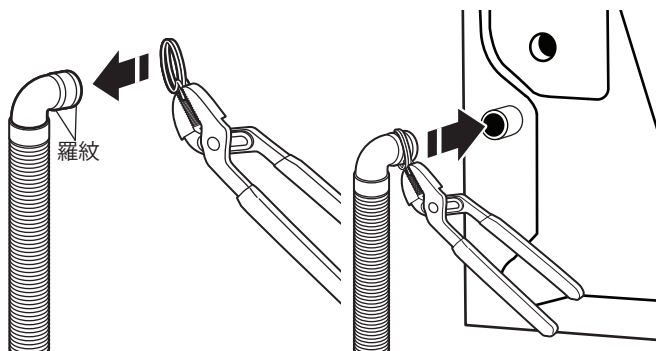

若排水管的彎管末端尚未安裝管夾，請用鉗子擠壓管夾，然後將其滑過彎頭末端，將其置中於羅紋之間，如圖所示。用鉗子擠壓管夾，將排水管的彎頭端部滑動到排水口上，並用管夾將它固定。

有關洗衣盆或立管排水管，請參閱以上/以下步驟。

若使用地面排水，請依照以上/以下步驟所示，取下預先安裝的排水管固定架。您可能需要具有個別方向的額外零件。請參閱「替代零件」。

安裝人員需負責將排水管安裝並固定到提供的下水道/排水管中，以免排水管從下水道/排水管中漏出或漏水。

### 取下排水管固定架（僅適用於地面排水安裝）

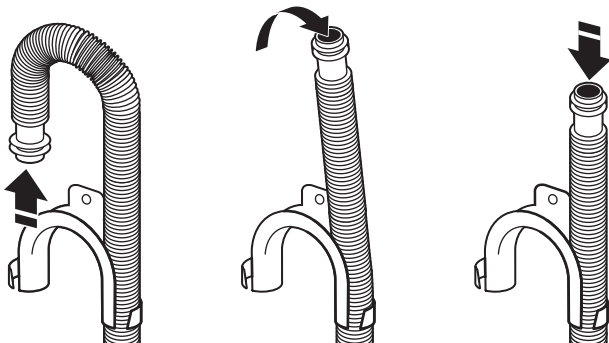

對於地面排水安裝，您需要從排水管的末端取下排水管固定架。您可能需要具有個別方向的額外零件。請參閱「替代零件」。

### 將排水管放入水塔

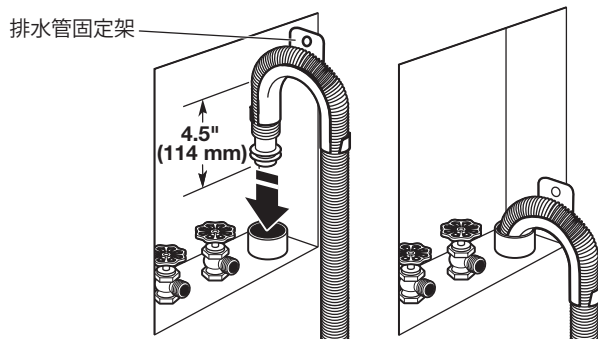

將軟管放入立管（如圖所示）或洗衣盆的頂部。

**重要事項：**排水管僅能插入立管內 4.5" (114 mm) 深，；請勿強行將多餘的軟管插入立管或放在洗衣盆底部。必須使用排水管固定架。

## 連接進水管

### 插入新的橡皮墊片

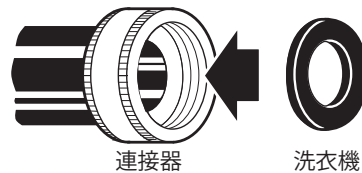

**重要事項：**為避免漏水，請檢查進水管兩端是否有橡皮墊片。必須使用含橡皮墊片的新進水管將機器連接到水龍頭。請勿使用舊軟管。請勿在沒有橡皮墊片情況下使用軟管。

### 將進水管連接到水龍頭

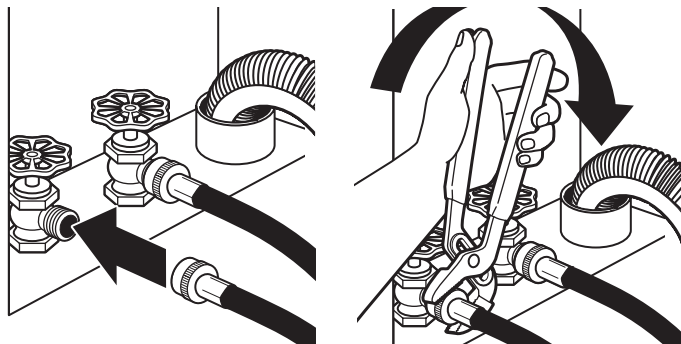

**重要事項：**連接水龍頭或機器時，請勿過度旋緊或在閥門上使用膠帶或密封劑。否則，將會導致損毀。將標示為「熱」的軟管連接到熱水龍頭。用手旋緊連接器，直到它固定在洗衣機上。用可調式鉗子將連接器再旋緊三分之二圈。對於冷水龍頭、標示「冷」的軟管重複此步驟。這兩條軟管均必須連接至機器，才能正常運作。

### 清理水管

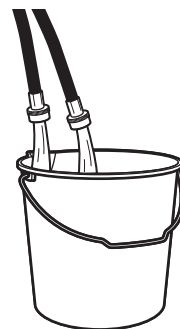

讓水通過進水管流入洗衣盆、排水管或桶幾秒鐘以避免堵塞。讓水繼續流動直到清澈。

### 將進水管連接到機器

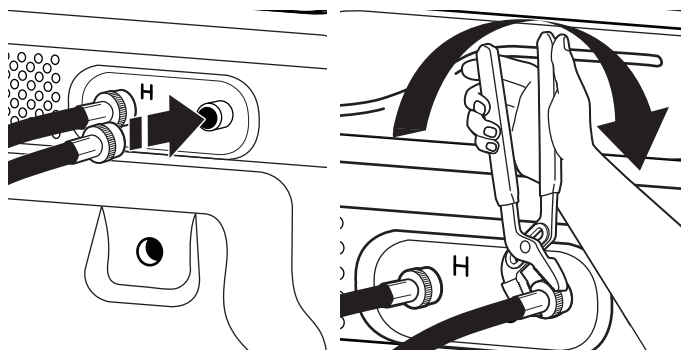

**重要事項：**為了降低軟管故障的風險，請每 5 年更換軟管。記錄軟管安裝或更換日期以備日後參考。

- 請勿過度擰緊軟管或在閥上使用膠帶或密封膠。此舉可能損壞閥。
- 若發現突起物、扭曲、割痕、磨損或漏水，定期檢查和更換水管。

將熱水軟管連接到熱水進水閥上。用手旋緊連接器，直到它緊貼。用可調式鉗子將連接器再旋緊三分之二圈。對冷水進水閥重複此步驟。

### 檢查是否有漏水

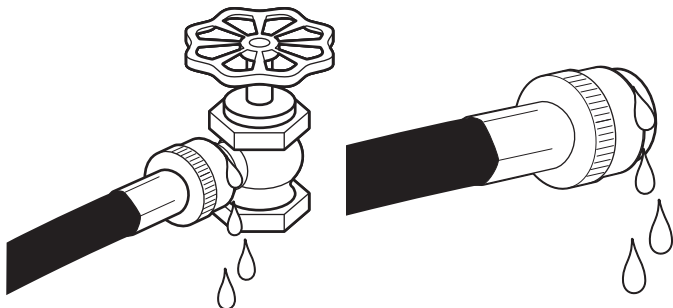

慢慢打開水龍頭檢查是否有漏水。可能有少量的水進入機器。它會在稍後排出。

### 將排水管固定

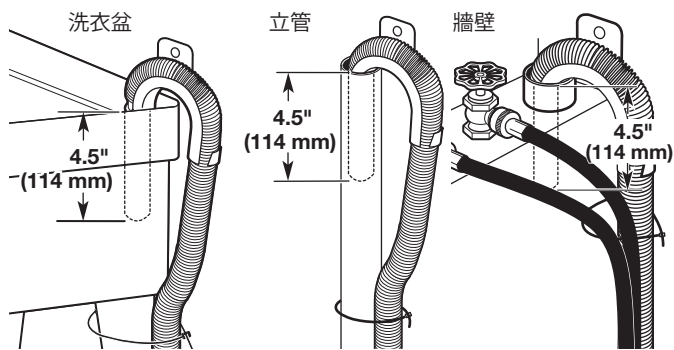

用繫線帶或串珠繫帶將排水管固定到洗衣盆支腳、排水立管，或牆上水塔的進水管。安裝人員要負責將排水軟管安裝並固定到提供的下水道/排水管中，以免排水管從下水道/排水管中漏出或漏水。

## 平放洗衣機

**重要事項：**平放您的機器可以減少過多的噪音和振動。

### 檢查機器的水平

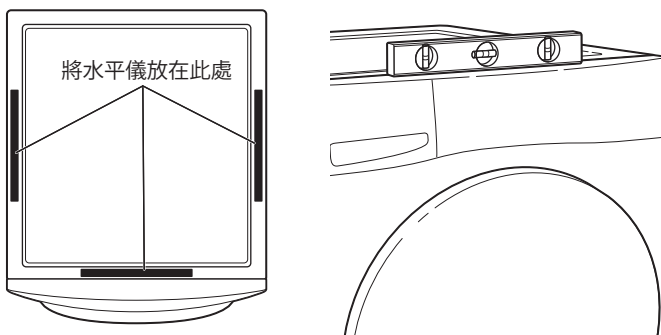

取出機器下方的硬紙板。將水平儀放在機器的頂部邊緣，檢查兩側和正面。如果不是水平狀態，請傾斜機器並依照「調整水平支腳」和「拴緊水平支腳」中所示，向上或向下調整水平支腳，視需要可重複進行。

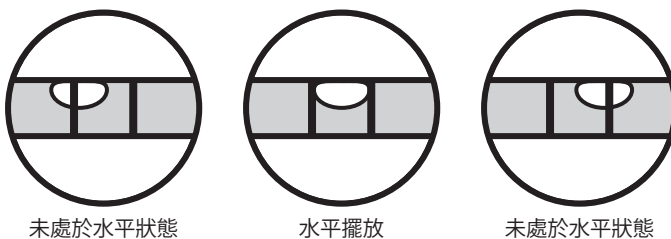

### 搖晃機器來測試支腳的接觸面



從頂部抓握機器並來回搖晃，確保所有四個支腳都牢固地放在地板上。重複步驟，從每一邊搖晃機器來測試。如果機器晃動，請調整水平支腳。如果四個水平支腳均已牢牢與地面接觸，請拴緊水平支腳。

### 調整水平支腳

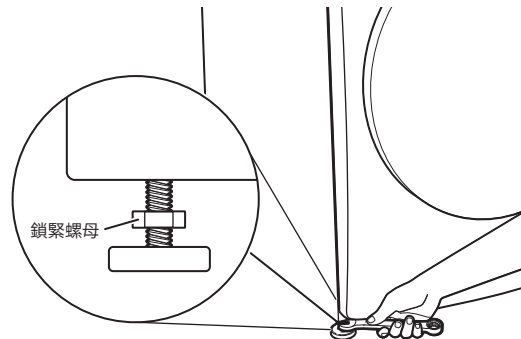

如果機器並未水平，用 9/16" (14 mm) 開口扳手或活動扳手，順時針轉動機腳上的鎖緊螺母，直到距離底座大約 1/2" (13 mm)。然後順時針轉動水平支腳以降低機器，或逆時針轉動以升高機器。支腳到底座底部的距離不要超過 2" (50 mm)。重新檢查機器的水平，並確保所有四個支腳都牢固接觸地面。視需要重複此步驟。

**實用秘訣：**您可能需要一個木塊或類似物體來撐起機器的正面大約 4" (102 mm)，以支撐機器的重量。

## 拴緊水平支腳

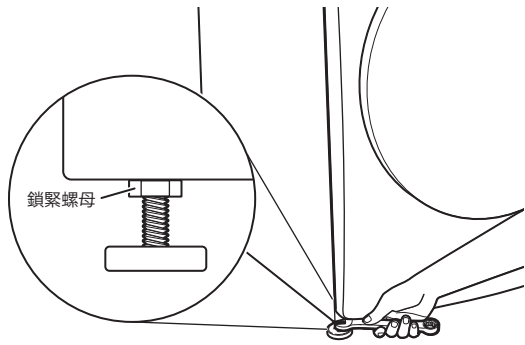

當機器處於水平狀態並且所有四個支腳都牢固地接觸地板時，請使用 9/16" (14 mm) 的開口扳手或活動扳手逆時針旋轉調平機腳上的防鬆螺母，使其牢牢拴緊在機器底座。

**實用秘訣：**您可能需要用木塊來撐起機器。

**警告**



### 觸電危險

- 將插頭插入一個三孔的接地電源插座上。
- 請勿拔掉接地插腳。
- 請勿使用轉接頭。
- 請勿使用延長線。
- 違反這些指示可能導致人員傷亡、失火或觸電。

## 將插頭插入一個三孔的接地電源插座

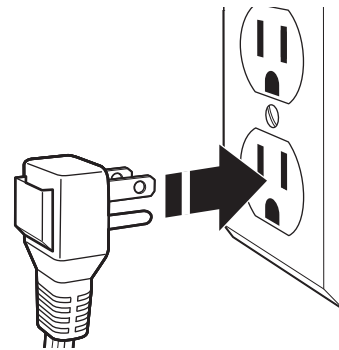

## 完成安裝檢核清單

- 檢查電氣要求。確保您的電源正確並使用建議的接地方法。
- 檢查確認清單上的零件已安裝完畢。若有遺留零件，請回顧所有步驟查找忽略的零件。
- 檢查確保所有工具齊全。檢查運輸材料是否已從機器完全清除。
- 檢查熱水管和冷水管是否均已連接，並且水龍頭已打開。
- 檢查水龍頭、閥門和進水管周圍是否有漏水。
- 取下控制板上的保護膠薄膜和機器上遺留的任何膠帶。
- 檢查並確定機器插頭插入一個三孔的接地電源插座。
- 處理/回收所有的包裝材料。
- 若要測試和清潔機器，請按「電源鍵」，然後選擇「快洗」，在沒有衣物的情況下運行。僅使用 HE 洗衣精，使用廠商建議中量衣物所用劑量的一半。



## 行程指南

本洗衣機具有獨特的使用者介面，協助您為衣物選擇最佳行程。以下「待洗衣料」、「洗衣方式」表格指引您如何以兩個步驟選擇最佳行程：

首先確認您正要清洗哪些衣物，按照衣物種類選擇對應的「待洗衣料」選項。接著按您的需求選擇「洗衣方式」，確認洗衣機應如何清洗衣物。選擇「待洗衣料」將自動選擇預設的「洗衣方式」，您可自行選擇是否調整「洗衣方式」。見下表瞭解更多詳情。

| 您想要清洗什麼？                | 「待洗衣料」行程選擇： |
|-------------------------|-------------|
| 棉質、亞麻布和混合衣物             | 一般          |
| 免燙衣料、襯衫/褲子、合成纖維、薄紗/花邊衣物 | 細緻          |
| 大型衣物，例如：小棉被、睡袋、夾克和可洗地毯  | 大物件         |
| 白色布料/衣服                 | 白色          |
| 亮色或深色亞麻和混合衣物            | 花色          |
| 布料堅固的毛巾和抹布              | 毛巾          |

| 想要如何清洗它們？          | 「洗衣方式」行程選擇： |
|--------------------|-------------|
| 一般                 | 標準          |
| 少些皺痕               | 除皺          |
| 強力清潔               | 強力洗滌        |
| 排除 99.9% 的三種常見居家細菌 | 消毒殺菌*       |
| 冷水溫和清潔             | 冷水          |
| 快速                 | 快洗          |

以粗體字顯示的設定和選項，是該洗衣行程的預設設定。為達成最佳保護衣物效果，選擇最適用於需要清洗的衣物之行程、選項和設定。請務必閱讀和遵循布料保養標籤，以及清洗產品說明。避免把衣物塞太滿。洗衣機塞得太滿，就無法妥善將衣物洗淨或脫水。如果選擇「洗衣 & 烘衣」或「單獨烘衣」，請放入最多一半衣物，這將最佳化烘乾性能和行程時間。並非每個行程都提供所有設定，且部份選項無法合併使用。並非所有機種都提供所有選項。

| 待洗衣料 | 洗衣方式 | 基本設定                   |                          |              | 更多選項 |       |      |         |            |
|------|------|------------------------|--------------------------|--------------|------|-------|------|---------|------------|
|      |      | 洗衣水溫                   | 脫水轉速                     | 衣物髒度         | 蒸氣   | 冷風清新® | 加強洗滌 | 洗衣 & 烘衣 | Load & Go™ |
| 一般   | 標準   | 熱<br>微熱<br>溫<br>涼<br>冷 | 高<br>中高<br>中<br>不脫水      | 輕<br>正常<br>重 | X    | X     | X    | X       | X          |
|      | 除皺   | 熱<br>微熱<br>溫<br>涼<br>冷 | 高<br>中高<br>中<br>慢<br>不脫水 | 輕<br>正常<br>重 | X    | X     | X    | X       | X          |
|      | 強力洗滌 | 熱<br>微熱<br>溫<br>涼<br>冷 | 高<br>中高<br>中<br>不脫水      | 輕<br>正常<br>重 | X    | X     | X    | X       | X          |

| 待洗衣料 | 洗衣方式  | 基本設定                   |                  |      | 更多選項 |       |      |         |            |
|------|-------|------------------------|------------------|------|------|-------|------|---------|------------|
|      |       | 洗衣水溫                   | 脫水轉速             | 衣物髒度 | 蒸氣   | 冷風清新® | 加強洗清 | 洗衣 & 烘衣 | Load & Go™ |
| 一般   | 消毒殺菌* | 熱                      | 高中高中             | 輕正常重 | X    | X     | X    | X       | X          |
|      | 冷水    | 熱<br>微熱<br>溫<br>涼<br>冷 | 高中高中<br>不脫水      | 輕正常重 |      | X     | X    | X       | X          |
|      | 快洗    | 熱<br>微熱<br>溫<br>涼<br>冷 | 高中高中<br>不脫水      | 輕正常重 | X    | X     | X    | X       | X          |
|      | 單獨烘衣  |                        |                  |      |      | X     |      |         |            |
| 細緻   | 標準    | 熱<br>微熱<br>溫<br>涼<br>冷 | 高中高中<br>慢<br>不脫水 | 輕正常重 | X    | X     | X    | X       | X          |
|      | 快洗    | 熱<br>微熱<br>溫<br>涼<br>冷 | 高中高中<br>慢<br>不脫水 | 輕正常重 | X    | X     | X    | X       | X          |
|      | 除皺    | 熱<br>微熱<br>溫<br>涼<br>冷 | 高中高中<br>慢<br>不脫水 | 輕正常重 | X    | X     | X    | X       | X          |
|      | 單獨烘衣  |                        |                  |      |      | X     |      |         |            |
|      | 強力洗滌  | 熱<br>微熱<br>溫<br>涼<br>冷 | 高中高中<br>慢<br>不脫水 | 輕正常重 | X    | X     | X    | X       | X          |

\*本行程去除衣服、床單和毛巾 99.9% 的大部份常見細菌。使用適用的最高洗衣水溫，確保能進行消毒作業。檢查衣物的建議洗衣水溫。經測試的細菌包括：克雷伯氏肺炎菌、銅綠假單胞菌和金黃色葡萄球菌。

| 待洗衣料 | 洗衣方式  | 基本設定                   |                              |              | 更多選項 |       |      |         |            |
|------|-------|------------------------|------------------------------|--------------|------|-------|------|---------|------------|
|      |       | 洗衣水溫                   | 脫水轉速                         | 衣物髒度         | 蒸氣   | 冷風清新® | 加強洗清 | 洗衣 & 烘衣 | Load & Go™ |
| 細緻   | 冷水    | 熱<br>微熱<br>溫<br>涼<br>冷 | 高<br>中<br>高<br>中<br>慢<br>不脫水 | 輕<br>正常<br>重 |      | X     | X    | X       | X          |
|      | 消毒殺菌* | 熱                      | 高<br>中<br>高<br>中<br>慢<br>不脫水 | 輕<br>正常<br>重 | X    | X     | X    | X       | X          |
| 大物件  | 標準    | 熱<br>微熱<br>溫<br>涼<br>冷 | 高<br>中<br>高<br>中<br>慢<br>不脫水 | 輕<br>正常<br>重 | X    | X     | X    | X       | X          |
|      | 快洗    | 熱<br>微熱<br>溫<br>涼<br>冷 | 高<br>中<br>高<br>中<br>慢<br>不脫水 | 輕<br>正常<br>重 | X    | X     | X    | X       | X          |
|      | 除皺    | 熱<br>微熱<br>溫<br>涼<br>冷 | 高<br>中<br>高<br>中<br>慢<br>不脫水 | 輕<br>正常<br>重 | X    | X     | X    | X       | X          |
|      | 強力洗滌  | 熱<br>微熱<br>溫<br>涼<br>冷 | 高<br>中<br>高<br>中<br>慢<br>不脫水 | 輕<br>正常<br>重 | X    | X     | X    | X       | X          |
|      | 單獨烘衣  |                        |                              |              |      | X     |      |         |            |
|      | 冷水    | 熱<br>微熱<br>溫<br>涼<br>冷 | 高<br>中<br>高<br>中<br>慢<br>不脫水 | 輕<br>正常<br>重 |      | X     | X    | X       | X          |

\*本行程去除衣服、床單和毛巾 99.9% 的大部份常見細菌。使用適用的最高洗衣水溫，確保能進行消毒作業。檢查衣物的建議洗衣水溫。經測試的細菌包括：克雷伯氏肺炎菌、銅綠假單胞菌和金黃色葡萄球菌。

| 待洗衣料 | 洗衣方式  | 基本設定                   |                          |                          | 更多選項         |       |      |         |            |
|------|-------|------------------------|--------------------------|--------------------------|--------------|-------|------|---------|------------|
|      |       | 洗衣水溫                   | 脫水轉速                     | 衣物髒度                     | 蒸氣           | 冷風清新® | 加強洗清 | 洗衣 & 烘衣 | Load & Go™ |
| 白色   | 標準    | 熱<br>微熱<br>溫<br>涼<br>冷 | 高<br>中高<br>中<br>慢<br>不脫水 | 輕<br>正常<br>重             | X            | X     | X    | X       | X          |
|      | 快洗    | 熱<br>微熱<br>溫<br>涼<br>冷 | 高<br>中高<br>中<br>慢<br>不脫水 | 輕<br>正常<br>重             | X            | X     | X    | X       | X          |
|      | 除皺    | 熱<br>微熱<br>溫<br>涼<br>冷 | 高<br>中高<br>中<br>慢<br>不脫水 | 輕<br>正常<br>重             | X            | X     | X    | X       | X          |
|      | 強力洗滌  | 熱<br>微熱<br>溫<br>涼<br>冷 | 高<br>中高<br>中<br>慢<br>不脫水 | 輕<br>正常<br>重             | X            | X     | X    | X       | X          |
|      | 冷水    | 熱<br>微熱<br>溫<br>涼<br>冷 | 高<br>中高<br>中<br>慢<br>不脫水 | 輕<br>正常<br>重             |              | X     | X    | X       | X          |
|      | 消毒殺菌* | 熱                      | 高<br>中高<br>中<br>慢<br>不脫水 | 輕<br>正常<br>重             | X            | X     | X    | X       | X          |
|      | 單獨烘衣  |                        |                          |                          |              | X     |      |         |            |
|      | 花色    | 標準                     | 熱<br>微熱<br>溫<br>涼<br>冷   | 高<br>中高<br>中<br>慢<br>不脫水 | 輕<br>正常<br>重 | X     | X    | X       | X          |

\*本行程去除衣服、床單和毛巾 99.9% 的大部份常見細菌。使用適用的最高洗衣水溫，確保能進行消毒作業。檢查衣物的建議洗衣水溫。經測試的細菌包括：克雷伯氏肺炎菌、銅綠假單胞菌和金黃色葡萄球菌。

| 待洗衣料 | 洗衣方式  | 基本設定                   |                          |              | 更多選項 |       |      |         |            |
|------|-------|------------------------|--------------------------|--------------|------|-------|------|---------|------------|
|      |       | 洗衣水溫                   | 脫水轉速                     | 衣物髒度         | 蒸氣   | 冷風清新® | 加強洗清 | 洗衣 & 烘衣 | Load & Go™ |
| 花色   | 快洗    | 熱<br>微熱<br>溫<br>涼<br>冷 | 高<br>中高<br>中<br>慢<br>不脫水 | 輕<br>正常<br>重 | X    | X     | X    | X       | X          |
|      | 除皺    | 熱<br>微熱<br>溫<br>涼<br>冷 | 高<br>中高<br>中<br>慢<br>不脫水 | 輕<br>正常<br>重 | X    | X     | X    | X       | X          |
|      | 強力洗滌  | 熱<br>微熱<br>溫<br>涼<br>冷 | 高<br>中高<br>中<br>慢<br>不脫水 | 輕<br>正常<br>重 | X    | X     | X    | X       | X          |
|      | 冷水    | 熱<br>微熱<br>溫<br>涼<br>冷 | 高<br>中高<br>中<br>慢<br>不脫水 | 輕<br>正常<br>重 |      | X     | X    | X       | X          |
|      | 消毒殺菌* | 熱                      | 高<br>中高<br>中<br>慢<br>不脫水 | 輕<br>正常<br>重 | X    | X     | X    | X       | X          |
|      | 單獨烘衣  |                        |                          |              |      | X     |      |         |            |
| 毛巾   | 標準    | 熱<br>微熱<br>溫<br>涼<br>冷 | 高<br>中高<br>中<br>慢<br>不脫水 | 輕<br>正常<br>重 | X    | X     | X    | X       | X          |
|      | 快洗    | 熱<br>微熱<br>溫<br>涼<br>冷 | 高<br>中高<br>中<br>慢<br>不脫水 | 輕<br>正常<br>重 | X    | X     | X    | X       | X          |

\*本行程去除衣服、床單和毛巾 99.9% 的大部份常見細菌。使用適用的最高洗衣水溫，確保能進行消毒作業。檢查衣物的建議洗衣水溫。經測試的細菌包括：克雷伯氏肺炎菌、銅綠假單胞菌和金黃色葡萄球菌。

| 待洗衣料 | 洗衣方式  | 基本設定                   |                          |              | 更多選項 |       |      |         |            |
|------|-------|------------------------|--------------------------|--------------|------|-------|------|---------|------------|
|      |       | 洗衣水溫                   | 脫水轉速                     | 衣物髒度         | 蒸氣   | 冷風清新® | 加強洗滌 | 洗衣 & 烘衣 | Load & Go™ |
| 毛巾   | 除皺    | 熱<br>微熱<br>溫<br>涼<br>冷 | 高<br>中高<br>中<br>慢<br>不脫水 | 輕<br>正常<br>重 | X    | X     | X    | X       | X          |
|      | 強力洗滌  | 熱<br>微熱<br>溫<br>涼<br>冷 | 高<br>中高<br>中<br>慢<br>不脫水 | 輕<br>正常<br>重 | X    | X     | X    | X       | X          |
|      | 冷水    | 熱<br>微熱<br>溫<br>涼<br>冷 | 高<br>中高<br>中<br>慢<br>不脫水 | 輕<br>正常<br>重 |      | X     | X    | X       | X          |
|      | 消毒殺菌* | 熱                      | 高<br>中高<br>中<br>慢<br>不脫水 | 輕<br>正常<br>重 | X    | X     | X    | X       | X          |
|      | 單獨烘衣  |                        |                          |              |      | X     |      |         |            |

\*本行程去除衣服、床單和毛巾 99.9% 的大部份常見細菌。使用適用的最高洗衣水溫，確保能進行消毒作業。檢查衣物的建議洗衣水溫。經測試的細菌包括：克雷伯氏肺炎菌、銅綠假單胞菌和金黃色葡萄球菌。

# 故障排除

首先，請嘗試此處的建議辦法，或造訪我們的網站：[www.whirlpool.com.tw](http://www.whirlpool.com.tw)

| 如果您經歷了  | 可能原因  | 解決方案   |
|---|---|--|
| <b>顯示畫面中顯示錯誤代碼（顯示 2 和 3 位數）</b>                                   |   |  |
| 一旦修正所有可能問題後，按壓 <b>POWER</b> （電源開關）一次，清除所有代碼。重新選擇和重新啟動行程。          |   |  |
| 顯示畫面將出現「Sd」或「Sud」（過多泡沫）   | 洗衣機有過多泡沫。洗衣機正在運行減少泡沫的例行作業。                  | 允許洗衣機繼續運行。僅使用 <b>HE</b> 洗衣精。請務必遵循洗衣精製造商的說明，並根據衣物量，決定洗衣精的用量。並非所有標示為「高效能」的洗衣精都內含相同配方，而減少泡沫的能力也有所不同。例如：天然、有機或自製 <b>HE</b> 洗衣精可能會產生大量泡沫。若您使用上述其中一種產品，並看到顯示畫面上出現「Sd」或「Sud」錯誤碼，考慮使用不同的 <b>HE</b> 洗衣精。                                |
| 顯示畫面顯示「Lo」後再顯示「FL」或「F8」後再顯示「E1」或「Lo」後再顯示「FL」或「F08」後再顯示「E01」（供水錯誤） | 檢查供水是否正常。                                   | 機門上鎖時機體將排水 8 分鐘。必須允許排水行程的完成，否則錯誤代碼無法重設。完成後，按壓 <b>POWER</b> （電源開關）一次，清除代碼。接著再按壓 <b>POWER</b> （電源開關），重新啟動洗衣機。若再次顯示代碼，致電維修部。<br>必須連接兩個管子，且水應流進進水閥。<br>冷熱水水龍頭都必須打開。<br>檢查進水閥網罩沒有堵塞。<br>清除進水管任何扭曲處。<br>若有使用，自動關閉連接器和管子都必須妥善安裝和正在運行。 |
|   | 檢查進水管是否妥善。                                  | 僅使用製造商建議的進水管。  |
| 顯示畫面顯示「F9」後再顯示「E1」或「F09」後再顯示「E01」（排水幫浦系統錯誤）                       | 檢查管線，確定已正確安裝排水管。排水管應延伸至立管的 4½" (11.4 cm) 處。 | 檢查已正確安裝排水管。<br>確定排水管沒有糾結、刺穿或堵塞。<br>取出管內任何堵塞物。<br>使用排水管固定架，並穩妥連接至漏盆或水槽。<br>若排水管末端離地面有 96" (2.4 m)，降低排水管的高度。   |
|   | 未使用 <b>HE</b> 洗衣精，或使用太多 <b>HE</b> 洗衣精。      | 僅使用 <b>HE</b> 洗衣精。經常測量洗衣精並根據衣物量和衣物髒度，遵循製造商的用量說明。   |
| 顯示畫面顯示「F5」後再顯示「E2」或「F05」後再顯示「E02」（機門無法上鎖）                         | 洗衣機門無法上鎖。                                   | 按壓 <b>POWER</b> （電源開關），取消行程。檢查機門已完全關閉且以拴上。檢查也許洗衣機內有衣物堵住機門，所以無法關門。  |
| 顯示畫面出現「rL」（取出衣物）  | 「affresh 槽洗淨」行程時偵測到滾筒內有衣物。                  | 取出滾筒的衣物，然後重新啟動「affresh 槽洗淨」行程。   |
| "PF"  | 如果在行程運轉期間斷電，從斷電狀態恢復運作時，畫面上會顯示此訊息。           | 按壓 <b>POWER</b> （電源開關）一次，清除代碼。接著再按壓 <b>POWER</b> （電源開關），重新啟動洗衣機。   |

# 故障排除

警告

**觸電危險**

將插頭插入一個三孔的接地電源插座上。  
 請勿拔掉接地插腳。  
 請勿使用轉接頭。  
 請勿使用延長線。  
 違反這些指示可能導致人員傷亡、失火或觸電。

首先，請嘗試此處的建議辦法，或造訪我們的網站：[www.whirlpool.com.tw](http://www.whirlpool.com.tw)

| 如果您經歷了                               | 可能原因                                    | 解決方案   |
|--------------------------------------|---|--|
| <b>顯示畫面中顯示錯誤代碼（顯示 2 和 3 位數）（續上頁）</b> |   |  |
| 顯示畫面顯示除上述外的 F# E# 或 F## E## 代碼       | 系統錯誤代碼。                                 | 按壓POWER（電源開關）一次，清除代碼。接著再按壓POWER（電源開關），重新啟動洗衣機。若再次顯示代碼，致電維修部。拔下洗衣機插頭 30 秒，然後再插上插頭。  |
| 洗衣機發出錯誤嗶聲                            | 未打開和關閉機門最少 3 個行程。                       | 此代碼可能在首次啟動洗衣機時出現。開啟和關閉機門，清除顯示。   |
| 按壓 START（啟動）時，洗衣機會發出嗶聲               | 洗衣機門關不緊。                                | 完全關上洗衣機門。  |
| 「槽洗淨」LED 燈在洗衣行程結束後閃爍（部份機種）           | 洗衣機已運行了 30 次洗衣行程，提醒您要運行「affresh 槽洗淨」行程。 | 運行「affresh 槽洗淨」行程。若未啟動「affresh 槽洗淨」行程，運行 3 次或以上的正常洗衣行程後，洗衣行程結束後，LED 燈將停止閃爍。完成 30 次以上的洗衣行程後，「affresh 槽洗淨」LED 燈將於特定洗衣行程結束後再度閃爍，作為提醒。 |
| 顯示畫面顯示「冷卻」                           | 如果衣物需要更多時間來冷卻，此圖示會在烘乾行程結束前顯示。           | 畫面上顯示圖示是正常的，當冷卻結束時，圖示就會消失。   |





## 故障排除

首先，請嘗試此處的建議辦法，或造訪我們的網站：[www.whirlpool.com.tw](http://www.whirlpool.com.tw)

| 如果您經歷了                 | 可能原因                  | 解決方案  |
|------------------------|-----------------------|---|
| <b>震動或不平衡</b>          |                       |   |
| 震動、搖晃或「前進後退」           | 支腳可能未和地板接觸且鎖死。        | 前腳和後腳必須穩妥與地板接觸，且洗衣機必須平放，才能正常運行。必須把鎖緊螺母牢牢拴緊在洗衣機底部。   |
|                        | 洗衣機也許未平放。             | 檢查地板是否彎曲或下垂。若地板不平，放一塊 3/4" (1.9 cm) 夾板在洗衣機底部，可減少噪音。不得將洗衣機安裝在架高的木平台上。<br>請參閱《安裝說明》中的「平放洗衣機」。         |
|                        | 衣物可能放置不均或太大件。         | 避免把衣物塞太滿。避免清洗單一衣物。<br>用額外幾種衣物平衡類似地毯或牛仔夾克之類的單一衣物。<br>衣物不適用所選行程。請參閱「洗衣機行程指南」和「使用您的洗衣機」。               |
|                        | 貨運螺栓也許還在洗衣機的背面。       | 參閱「安裝說明」的「取下洗衣機上的運送螺栓」。   |
| <b>噪音</b>              |                       |   |
| 喀嗒或金屬噪音                | 機門上鎖或解鎖。              | 開始某個行程後滾筒將局部轉動，且機門會上鎖。行程結束前機門都將上鎖。這是正常現象。   |
|                        | 洗衣機排水系統內有物件。          | 洗衣前清空口袋。零錢之類的零散物品可能掉落至洗衣機滾筒和水槽之間，進而堵住幫浦。也許需要致電維修部清除物品。<br>聽到衣物金屬物品，例如：金屬按扣、搭扣或拉鍊與不鏽鋼滾筒接觸後發出聲音是正常現象。 |
| 淙淙聲或嗡嗡聲                | 洗衣機也許正在排水。            | 幫浦也許會發出嗡嗡聲，並偶爾發出淙淙聲或在轉動/排水行程排去最後水量時發出沖水聲。這在行程特定階段是正常現象。   |
| 滾動或晃動，並偶爾發出喀嗒聲（在低速轉動時） | 平衡系統的鋼珠正在平均衣物。        | 這在行程特定階段是正常現象。  |
| <b>漏水</b>              |                       |   |
| 檢查已遵循正確的排水管安裝說明。       | 未緊密連接注水管。             | 拴緊注水管的連接。   |
|                        | 注水管的橡膠墊片。             | 穩妥拴緊所有四個注水管的橡膠墊圈。   |
|                        | 排水管連接。                | 檢查已妥善連接排水管至漏盆或水槽。   |
|                        | 針對部份機種：未妥善安裝排水幫浦過濾器。  | 針對部份機種：確定已把過濾器放在幫浦的正確位置。<br>參閱「清潔排水幫浦過濾器/排出殘留水份」。   |
|                        | 檢查家用管線是否有洩漏、堵塞或漏水。    | 水流可能會因為水槽或漏盆堵塞而回流。檢查所有家用管線是否有洩漏（水槽、漏盆和水龍頭）。   |
|                        | 排水管末端的固定接頭（或尼龍網）也許堵塞。 | 取下排水管的固定接頭/尼龍網。   |

# 故障排除

 **警告**



**觸電危險**

將插頭插入一個三孔的接地電源插座上。

請勿拔掉接地插腳。

請勿使用轉接頭。

請勿使用延長線。

違反這些指示可能導致人員傷亡、失火或觸電。

首先，請嘗試此處的建議辦法，或造訪我們的網站：[www.whirlpool.com.tw](http://www.whirlpool.com.tw)

| 如果您經歷了               | 可能原因                            | 解決方案   |
|----------------------|---------------------------------|--|
| <b>漏水（續上頁）</b>       |                                 |  |
| 機門或櫥櫃後方漏水或滲出泡沫       | 未使用 HE 洗衣精，或使用太多 HE 洗衣精。        | 僅使用 HE 洗衣精。一般洗衣精的泡沫可能導致機門或櫥櫃後方洩漏。經常測量洗衣精並根據衣物量要求，遵循製造商的用量說明。 |
|                      | 運行「槽洗淨」行程時使用增稠、易倒或不噴濺的漂白劑。      | 運行「affresh 槽洗淨」行程時使用「affresh 槽洗錠」或一般的不增稠漂白劑。                 |
|                      | 機門玻璃上有殘留物。                      | 偶爾清潔玻璃窗下側，避免潛在的洩漏問題。   |
|                      | 「加衣」時打開了機門。                     | 行程開始後開門，然後水從門內滴落。  |
| 機門四周漏水。              | 內門玻璃沾有頭髮、絨毛或其他殘留物，以致於封條未與門膠圈密封。 | 清潔內門窗戶和門膠圈。參閱「洗衣機維護」部份的「清潔門膠圈」。                              |
| <b>洗衣機未如預期的妥善運行</b>  |                                 |  |
| 衣物未全部浸泡於水中           | 機門看不到水位，或水位未超過全部衣物。             | 這是 HE 滾筒式洗衣機的正常現象。洗衣機感應到衣物量，並注入正確的水量，以達成最佳清潔效果。              |
| 洗衣機未運行或注水；洗衣機停止運作    | 檢查妥善的水源。                        | 必須連接兩個管子，且水應流進進水閥。   |
|                      |                                 | 冷熱水水龍頭都必須開啟。   |
|                      |                                 | 檢查進水閥網罩沒有堵塞。   |
| 洗衣機未運行或注水；洗衣機停止運作    | 檢查正常的電源供應。                      | 檢查進水管任何扭曲處，此現象可能限制水流。  |
|                      |                                 | 將電源線插入一個 3 腳的接地電源插座上。  |
|                      |                                 | 請勿使用延長線。   |
|                      |                                 | 確保插座有電源。   |
|                      |                                 | 不得插入至 GFCI（接地故障斷路器）。   |
| 檢查電源，或致電電工，檢查電壓是否過低。 |                                 |  |
|                      |                                 | 重設跳開的斷路器。更換任何燒壞的保險絲。   |
|                      |                                 | <b>備註：</b> 若問題持續，聯絡電子技工。                                     |

# 故障排除

首先，請嘗試此處的建議辦法，或造訪我們的網站：[www.whirlpool.com.tw](http://www.whirlpool.com.tw)

| 如果您經歷了                    | 可能原因  | 解決方案  |
|---------------------------|---|---|
| <b>洗衣機未如預期的妥善運行 (續上頁)</b> |   |   |
| 洗衣機未運行或注水；洗衣機停止運作 (續上頁)   | 正在感應衣物量。  | 感應衣物量後，將根據此重量顯示預計時間並開始加水。   |
|                           | 正常的洗衣機運作。   | 機門必須全部關閉並上栓，洗衣機才能運行。  |
|                           |   | 洗衣機於特定行程期間將暫停約 2 分鐘。允許行程繼續。有些行程會有滾動和浸泡階段。   |
|                           |   | 洗衣機也許會停止，以減少泡沫。僅使用適量的 HE 洗衣精。   |
|                           |   | 「冷水」於行程開始時會用略少的水，以提供高濃度的洗衣精，進行優化的清潔行動。以此濃度滾動後，會用較多的水來完成清洗。                                |
|                           |   | 在「槽洗淨」行程的前 20 分鐘，洗衣機將啟動蒸氣，但滾筒不會轉動或注水。在此初步階段您將看到門玻璃上的凝結作用。若您正在使用「槽洗錠」，它在蒸氣階段不會全部溶解。這是正常現象。 |
|                           | 洗衣機門沒有關緊。   | 洗衣機運行期間機門必須關閉。  |
|                           | 針對部份機種：Load & Go 洗劑智慧投放盒未穩妥放在洗衣機內。                                | 確定 Load & Go 洗劑智慧投放盒已穩妥放在洗衣機內，且已緊密關閉洗劑智慧投放盒的蓋子。   |
|                           | 未按建議將衣物放入洗衣機內。  | 取出數件衣物，再於洗衣筒內平均放置衣物。關門，然後觸碰並按住「啟動/暫停」。  |
|                           |   | 行程開始後不要放入超過 1 或 2 件衣物，避免把洗衣機塞滿或衣物放置不平均。   |
| 不要加水至洗衣機。                 |   |   |
| 未使用 HE 洗衣精，或使用太多 HE 洗衣精。  | 僅使用 HE 洗衣精。一般洗衣劑起的泡沫可能會減緩或停止洗衣機運行。請務必測量洗衣劑用量，並根據衣物量要求，遵循製造商的用量說明。 |   |
|                           | 要清除泡沫，取消行程。選擇「單獨脫水」與「加強洗清」。觸碰「啟動/暫停」。請勿加入更多洗衣精。                   |   |
|                           | 若使用單劑量洗衣精，請確認已停用 Load & Go。                                       |   |
| 確定行程之間沒有把門打開。             | 完成任何洗衣行程後，必須開門，然後在開始新行程時，再關門。                                     |   |
| 洗衣機沒有排水/轉動；衣物仍濕           | 排水管應延伸至立管的 4.5" (11.4 cm) 處。                                      | 檢查已正確安裝排水管。使用排水管固定架，並穩妥連接至漏盆或水槽。不要用膠帶黏住排水管的開口。  |
|                           | 排水管堵塞或排水管末端的高度離地面超過 96" (2.4 m)。                                  | 若排水管末端離地面有 96" (2.4 m)，降低排水管的高度。取出管內任何堵塞物。請參閱「安裝說明」中的「安裝要求」。                              |
|                           | 排水管末端的固定接頭/尼龍網堵塞。   | 取下排水管的固定接頭/尼龍網。   |
|                           | 排水管在立管內擠壓的太緊，或是用膠帶黏在立管商。  | 排水管應鬆鬆，且穩妥與立管接合。不得用膠帶黏住排水管。水管需要透氣縫隙。參閱「安裝說明」的「連接排水管」。                                     |

## 故障排除

首先，請嘗試此處的建議辦法，或造訪我們的網站：[www.whirlpool.com.tw](http://www.whirlpool.com.tw)

| 如果您經歷了                   | 可能原因                                      | 解決方案   |
|--------------------------|---|--|
| <b>洗衣機未如預期的妥善運行（續上頁）</b> |   |  |
| 洗衣機沒有排水/轉動；衣物仍濕（續上頁）     | 使用轉速較慢的行程。                                | 轉速較慢行程比轉速較快行程的去水力低。針對您的衣物選擇建議的行程/轉速。   |
|                          | 未按建議將衣物放入洗衣機內。                            | 塞太滿或未平均放置的衣物也許無法讓洗衣機正確轉動，因此衣物比正常狀況殘留更多水分。參閱「行程指南」，瞭解每個行程的建議衣物量。  |
|                          | 衣物也許放置得不平均。                               | 避免清洗單一衣物。用額外幾種衣物平衡類似地毯或牛仔夾克之類的單一衣物。  |
|                          | 未使用 HE 洗衣精，或使用太多 HE 洗衣精。                  | 僅使用 HE 洗衣精。一般洗衣精起的泡沫，或使用太多洗衣精，可能會減緩或停止洗衣機排水或轉動。經常測量洗衣精並根據衣物量，遵循製造商的用量說明。欲清除過多泡沫，選擇「單獨脫水」與「加強洗清」。請勿加入更多洗衣精。 |
|                          | 有些小物品可能會掉落至幫浦，或堵在洗衣機滾筒和外槽之間。              | 檢查滾筒，滾筒孔洞是否沾黏任何物品。請清空衣物的口袋，若清洗小物品，使用洗衣袋。   |
|                          | 針對部份機種：排水幫浦過濾器過髒。                         | 針對部份機種：清潔排水幫浦過濾器。參閱「清潔排水幫浦過濾器/排出殘留水份」。   |
|                          | 已取消洗衣行程，且在排水前打開機門。                        | 運行「單獨脫水」，清除任何過多水份。   |
| 洗衣機在沒有水的情況下空轉衣物。         | 洗衣機正在測量乾燥衣物的質量。                           | 測量是正常作業，確保為衣物設定最佳行程時間。   |
| 洗衣行程結束後門上鎖。              | 洗衣行程結束後洗衣機仍殘留水份。                          | 選擇「單獨脫水」，排去殘留在洗衣機內的任何水份。排水結束後洗衣機門將解鎖。  |
| 機門將不會解鎖。                 | 機門將於行程開始時上鎖。                              | 若「加衣」燈亮起，觸碰「啟動/暫停」一次。機門將解鎖。  |
| 洗衣或洗清溫度不正確或錯誤            | 檢查妥善的水源。                                  | 確保沒有錯誤連接冷熱水進水管。  |
|                          |   | 兩條管子都必須連接至洗衣機和水龍頭，且都有冷熱水流進進水閥。   |
|                          |   | 檢查進水閥網罩沒有堵塞。   |
| 清洗許多衣物。                  | 清除管子內任何扭曲處。                               | 您的熱水槽也許沒有足夠的熱水，來供應熱水或暖水洗衣的次數。這是正常現象。   |
| 理想的設定或選項沒有亮起。            | 為達成最佳效果，並非每個行程都提供所有設定，且部份選項無法合併使用。        | 參閱「行程指南」，瞭解每個行程的適用設定和選項。   |
| 未洗清衣物                    | 檢查妥善的水源。                                  | 確保沒有錯誤連接冷熱水進水管。  |
|                          |   | 必須連接兩個管子，且水應流進進水閥。   |
|                          |   | 冷熱水水龍頭都必須打開。   |
|                          |   | 檢查進水閥網罩沒有堵塞。   |
|                          |   | 清除進水管任何扭曲處。  |
|                          | 未使用 HE 洗衣精，或使用太多 HE 洗衣精。                  | 來自非 HE 高效能洗衣劑的泡沫可能讓洗衣機未正確運行。   |
|                          | 僅使用 HE 洗衣精。經常測量洗衣精並根據衣物量和衣物髒度，遵循製造商的用量說明。 |  |

## 故障排除

首先，請嘗試此處的建議辦法，或造訪我們的網站：[www.whirlpool.com.tw](http://www.whirlpool.com.tw)

| 如果您經歷了                   | 可能原因                     | 解決方案   |
|--------------------------|--------------------------|--|
| <b>洗衣機未如預期的妥善運行（續上頁）</b> |                          |  |
| 未洗清衣物（續上頁）               | 未按建議將衣物放入洗衣機內。           | 避免把衣物塞太滿。洗衣機塞得太滿，就無法妥善洗清衣物。僅放入乾燥衣物。參閱「行程指南」，瞭解每個行程的建議衣物量。                |
|                          |                          | 使用待洗布料專用的行程。<br>洗衣機啟動後僅放入一或兩件衣物。   |
|                          | 衣物也許放置得不平均。              | 若未平均放置衣物，將開始一個重新分佈衣物的洗衣流程。此舉可能延長行程時間。避免清洗單一衣物。用額外幾種衣物平衡類似地毯或牛仔夾克之類的單一衣物。 |
| 衣物皺褶、扭結或纏繞。              | 未按建議將衣物放入洗衣機內。           | 放入適量，以致能移動自在的衣物量。衣物須能自在移動，才能減少皺褶和纏繞。參閱「行程指南」，瞭解每個行程的建議衣物量。               |
|                          |                          | 混合不同類型的衣物，減少纏繞。選擇適合洗衣類型的建議行程。  |
|                          | 衣物的洗衣時間太久。               | 選擇較低衣物髒度。注意：選擇較高衣物髒度，不見得就能深層清洗該衣物。                                       |
|                          | 洗衣轉速太快。                  | 選擇較低轉速。注意：轉速低時，衣物比用轉速高行程清洗為濕。  |
|                          | 未即時取出洗衣機的衣物。             | 即時取出洗衣機的衣物，或若行程結束時無法取出衣物，使用「自動冷風清新®」選項。                                  |
|                          | 未為須清洗衣物選擇正確的行程。          | 選擇 <b>Delicates</b> （細緻）行程或其他慢速行程，減少皺褶。                                  |
|                          | 洗衣水不夠暖，無法撫平皺褶。           | 若對衣物安全無礙，使用溫水或熱水。  |
| 未清潔或去除污漬                 | 未按建議將衣物放入洗衣機內。           | 放入適量，以致能移動自在的衣物量。衣物應能移動自如，才能取得最佳清潔效果。參閱「行程指南」，瞭解每個行程的建議衣物量。              |
|                          |                          | 洗衣機啟動後僅放入一或兩件衣物。   |
|                          | 未使用 HE 洗衣精，或使用太多 HE 洗衣精。 | 僅使用 HE 洗衣精。經常測量洗衣精並根據衣物量和衣物髒度，遵循製造商的用量說明。                                |
|                          | 硬水或水中含高等級的鐵（鐵鏽）。         | 您可能需要安裝軟水機及/或鐵質過濾器。  |
|                          | 使用衣物柔軟晶球。                | 本洗衣機若放入輸送球，也許無法正常運行。倒入衣物柔軟劑至衣物柔軟劑投放格內。                                   |
|                          | 低速行程使用洗衣粉。               | 考慮使用洗衣精。   |

## 故障排除

首先，請嘗試此處的建議辦法，或造訪我們的網站：[www.whirlpool.com.tw](http://www.whirlpool.com.tw)

| 如果您經歷了                    | 可能原因                                     | 解決方案   |
|---------------------------|--|--|
| <b>洗衣機未如預期的妥善運行 (續上頁)</b> |  |  |
| 未清潔或去除污漬<br>(續上頁)         | 沒有按衣物類型使用正確的行程。                          | 使用較高衣物髒度設定和暖水洗衣，增進清潔效能。                        |
|                           |  | 使用「Quick Wash (少量快洗)」行程時只能洗少數幾件衣服。             |
|                           |  | 用「白色」和「厚重/衣量多」行程清洗骯髒衣物。                        |
|                           |  | 若為極為骯髒的衣物，增加加強洗清。                              |
|                           | 未使用洗劑盒。                                  | 使用洗劑盒，避免漂白劑和衣物柔軟精產生的污漬。                        |
|                           |  | 開始行程前注入洗劑至洗劑盒。                                 |
|                           |  | 針對部份機種：確定 Load & Go (部份機種) 洗劑智慧投放盒有加入洗劑。       |
|                           |  | 避免注入太多洗劑至洗劑盒。                                  |
|                           | 除直接在衣物上具體說明的產品外，不得添加其他產品。                |  |
| 洗劑盒是空的。                   | 注入 HE 高效能洗衣劑至洗劑盒的「MAX」線。                 |  |
| 洗劑盒沒有確實就定位。               | 拉出洗劑盒、注入洗衣劑，再把它滑進定位。                     |  |
| 未合併清洗類似顏色的衣物。             | 合併清洗類似顏色的衣物，並在完成行程後立即取出衣物，能避免衣物染色。       |  |
| 使用硬水或洗衣精不足。               | 用冷水或硬水清洗極骯髒衣物時，增加較多洗衣精。                  |  |
|                           | 在 (部份機種) 中，按壓「水硬度」，變更水硬度為「硬」。            |  |
| 異味                        | 未按建議進行每月維護。                              | 每月或運行 30 個行程後，運行「槽洗淨」。請參閱「洗衣機維護」部份的「洗衣機保養」。    |
|                           |  | 行程完成後立即取出洗衣機的衣物。若完成清洗後無法立即從洗衣機取出衣物，使用「冷風清新」選項。 |
|                           | 未使用 HE 洗衣精，或使用太多 HE 洗衣精。                 | 僅使用 HE 洗衣精。確定要正確測量。經常遵循製造商的說明。                 |
|                           |  | 請參閱「洗衣機保養」部份。                                  |
| 用後門沒有維持打開。                | 本洗衣機配備緊密封條，避免水滲漏。為避免氣味，讓機門打開，以使用後洗衣機能風乾。 |  |
| 布料損壞                      | 洗衣行程期間口袋理有尖銳物品。                          | 洗衣前清空口袋、拉上拉鍊、扣上按扣或鉤子固件，避免鉤破和撕裂衣物。              |
|                           | 繩子和帶子可能會纏繞。                              | 開始清洗衣物前，繫上所有繩子和帶子。                             |
|                           | 洗衣前衣物可能就已毀損。                             | 洗衣前修補接縫處的撕裂口和斷線。                               |
|                           | 若洗衣機塞太滿，將可能會損壞布料。                        | 避免把衣物塞太滿。僅放入乾燥衣物。                              |
|                           |  | 使用待洗布料專用的行程。                                   |
|                           |  | 洗衣機啟動後僅放入一或兩件衣物。                               |
|                           | 若機門夾住某件衣物、或把它卡在機門窗戶和橡膠封條之間，將可能會損壞布料。     | 不要將過量衣物裝入洗衣機。                                  |
|                           |  | 請將衣物完全推入洗衣機。                                   |
| 也許未正確添加液氯漂白劑。             | 不得將液態含氯漂白劑直接倒進衣物裡。擦拭溢出的漂白劑。              |  |
|                           | 未稀釋的漂白劑可能會損壞布料。不得使用超過製造商建議的用量。           |  |

## 故障排除

首先，請嘗試此處的建議辦法，或造訪我們的網站：[www.whirlpool.com.tw](http://www.whirlpool.com.tw)

| 如果您經歷了                   | 可能原因                               | 解決方案   |
|--------------------------|------------------------------------|--|
| <b>洗衣機未如預期的妥善運行（續上頁）</b> |                                    |  |
| 灰白、骯髒的顏色                 | 未妥善分類衣物。                           | 混合白色和有色衣物共洗可能會讓衣物染色。從白色和淺色衣物中取出深色衣物。   |
|                          | 洗衣溫度太低。                            | 若衣物可用，則使用熱水或溫水。確定您的熱水系統足以供應熱水洗衣。   |
|                          | 使用硬水或洗衣精不足。                        | 用冷水或硬水清洗極骯髒衣物時，增加較多洗衣精。  |
| 洗劑盒操作不正確。                | 洗劑盒堵塞或太早配送洗劑。                      | 不要過度注入洗劑至洗劑盒。注入太多洗劑能讓洗劑盒立即配送洗劑。  |
|                          |                                    | 開始行程前注入洗劑至洗劑盒。   |
|                          | 漂白劑投放格內未使用液態含氯漂白劑。                 | 低水壓家庭可能有洗劑盒殘留洗衣粉的現象。為避免此現象，視您的衣物和情況而定，可選擇用暖水洗衣。  |
|                          | 行程完成後有水殘留於洗劑盒。                     | 只能將液態含氯漂白劑注入於漂白劑投放格。<br>行程完成後有少量水殘留於洗劑盒是正常現象。  |
| 洗衣膠囊沒有溶解                 | 加入膠囊的程序不正確。                        | 確定是在放入衣物前加入膠囊。不要將膠囊加至洗劑盒。遵循製造商說明，避免損壞衣物。   |
| 行程時間變更，或行程時間太長           | 正常的洗衣機運作。                          | 行程時間按水壓、水溫、洗衣精和衣物而自動變更。您選擇的選項也將影響行程時間。   |
|                          | 洗衣機有過多泡沫。                          | 偵測到過多泡沫時，將自動啟動特殊的泡沫例行作業，以清除過多泡沫，同時確保妥善洗清衣物。此作業將增加原有行程的運行時間。  |
|                          | 衣物也許放置得不平均。                        | 若未平均放置衣物，將開始一個重新分佈衣物的洗衣流程。此舉可能延長行程時間。避免清洗單一衣物。用額外幾種衣物平衡類似地毯或牛仔夾克之類的單一衣物。                               |
|                          | 沒有按衣物類型使用正確的行程。                    | 「快洗」行程旨在清洗少量略髒衣物（2-4 件）。若用此行程清洗大量衣物，行程時間將增加。<br>使用「快洗」或「細緻」行程時，您應清洗少量衣物。此舉確保能輕柔清洗衣物，同時不增加行程時間。         |
| 控制鍵無回應。                  | <b>Control Lock</b> （控制鎖）已 ON（開啟）。 | 按壓 <b>Control Lock</b> （控制鎖）3 秒，解鎖控制鍵。對於按住 <b>Control Lock</b> （控制鎖）的每一秒，顯示將倒數計時一秒，您將看到「3」、「2」，然後是「1」。 |
| <b>烘乾結果</b>              |                                    |  |
| 衣物烘乾效果不滿意，或烘乾時間太長        | 衣物過大、過重，無法迅速烘乾。                    | 分開衣物，讓衣物可以順暢滾動。滾筒內放入四分之一滿以下的衣物，可以改善烘乾效能與行程時間。運行高脫水轉速行程。  |
| 衣物上的絨毛                   | 機門膠圈下方區域有棉絮堵塞。                     | 輕輕拉回橡膠的機門膠圈，並用 <b>affresh</b> 機器清潔拭紙有紋路的一面清潔棉絮。  |
|                          | 針對部份機種：排水幫浦過濾器有棉絮堵塞。               | 針對部份機種：清潔排水幫浦過濾器。參閱「清潔排水幫浦過濾器/排出殘留水份」。您應偶爾執行這程序。   |

首先，請嘗試此處的建議辦法，或造訪我們的網站：[www.whirlpool.com.tw](http://www.whirlpool.com.tw)

| 如果您經歷了    | 可能原因              | 解決方案   |
|-----------|-------------------|--|
| 烘乾結果（續上頁） |                   |  |
| 烘乾後的衣物起皺。 | 衣物在烘乾行程結束後未立即取出。  | 烘乾行程結束時立即取出衣物，或使用「自動冷風清新®」選項。                            |
|           | 洗衣機完全塞滿。          | 烘乾可以順暢滾動的較少衣物。滾筒內放入四分之一滿以下的衣物，可以改善烘乾效能與行程時間。結果可能依布料類型而異。 |
| 衣物過熱      | 在行程的冷卻程序完成前即取出衣物。 | 讓烘乾行程完成降溫程序，再把衣物取出。如果在行程的冷卻程序完成前取消並立即取出衣物，衣物就會非常燙。       |



## PRODUCT SPECIFICATIONS

| Models                          | <b>8TWFC6810LW</b>                  | <b>8TWFC6820LW</b>                  | <b>8TWFC6820LC</b>                  |
|---------------------------------|-------------------------------------|-------------------------------------|-------------------------------------|
| Product name                    | Washer Dryer                        | Washer Dryer                        | Washer Dryer                        |
| Power supply                    | 120 V / 60 Hz                       | 120 V / 60 Hz                       | 120 V / 60 Hz                       |
| Maximum wash load (dry clothes) | 15.0 kg                             | 17.0 kg                             | 17.0 kg                             |
| Maximum dry load (dry clothes)  | 10.0 kg                             | 10.0 kg                             | 10.0 kg                             |
| Water Pressure                  | 0.03-0.7 MPa                        | 0.03-0.7 MPa                        | 0.03-0.7 MPa                        |
| Rated power                     | Washing 1,000 W /<br>Drying 1,200 W | Washing 1,000 W /<br>Drying 1,200 W | Washing 1,000 W /<br>Drying 1,200 W |
| Maximum spin speed              | 1,200 rpm                           | 1,200 rpm                           | 1,200 rpm                           |
| Product color (end digit)       | W=White                             | W=White                             | C=Chrome Shadow                     |
| Weight                          | 103 kg                              | 103 kg                              | 103 kg                              |
| External dimensions (H x W x D) | 982 x 686 x 802 (mm)                | 982 x 686 x 802 (mm)                | 982 x 686 x 802 (mm)                |

**NOTE:** Actual specifications are as shown on machine nameplate.

For information on RoHS, please visit the official website [www.whirlpool.com.tw](http://www.whirlpool.com.tw).

# ALL-IN-ONE WASHER DRYER SAFETY

## Your safety and the safety of others are very important.

We have provided many important safety messages in this manual and on your appliance. Always read and obey all safety messages.



This is the safety alert symbol.

This symbol alerts you to potential hazards that can kill or hurt you and others.

All safety messages will follow the safety alert symbol and either the word “DANGER” or “WARNING.” These words mean:

**! DANGER**

**You can be killed or seriously injured if you don't immediately follow instructions.**

**! WARNING**

**You can be killed or seriously injured if you don't follow instructions.**

All safety messages will tell you what the potential hazard is, tell you how to reduce the chance of injury, and tell you what can happen if the instructions are not followed.

## IMPORTANT SAFETY INSTRUCTIONS

**WARNING:** To reduce the risk of fire, electric shock, or injury to persons when using your appliance, follow basic precautions, including the following:

- Read all instructions before using the appliance.
- Do not wash or dry articles that have been previously cleaned in, washed in, soaked in, or spotted with gasoline, dry-cleaning solvents, or other flammable or explosive substances, as they give off vapors that could ignite or explode.
- Do not add gasoline, dry-cleaning solvents, or other flammable or explosive substances to the wash water. These substances give off vapors that could ignite or explode.
- Under certain conditions, hydrogen gas may be produced in a hot-water system that has not been used for 2 weeks or more. **HYDROGEN GAS IS EXPLOSIVE.** If the hot-water system has not been used for such a period, before using a Washer Dryer, turn on all hot-water faucets and let the water flow from each for several minutes. This will release any accumulated hydrogen gas. As the gas is flammable, do not smoke or use an open flame during this time.
- Do not allow children to play on or in the appliance. Close supervision of children is necessary when the appliance is used near children.
- Before the appliance is removed from service or discarded, remove the door.
- Do not reach into the appliance if the tub is moving.
- Do not install or store this appliance where it will be exposed to the weather.
- Do not tamper with controls.
- Do not repair or replace any part of the appliance or attempt any servicing unless specifically recommended in the user maintenance instructions or in published user-repair instructions that you understand and have the skills to carry out.
- Do not use replacement parts that have not been recommended by the manufacturer (e.g. parts made at home using a 3D printer).
- See the Installation Instructions for grounding requirements and installation.
- This appliance is not designed to be used by people (including children) with physical, sensory, or mental abilities reduced, or with lack of experience and knowledge, unless it has been given instruction or supervision regarding the use of the appliance.
- Do not place items exposed to cooking oils in your Washer Dryer. Items contaminated with cooking oils may contribute to a chemical reaction that could cause a load to catch fire. To reduce the risk of fire due to contaminated loads, the final part of a drying cycle occurs without heat (cool down period).
- If the power cord is damaged, it must be replaced by the manufacturer or its service agent or by qualified personnel to avoid danger.
- The appliance must not be installed behind a lockable door, a sliding door or a door with a hinge on the opposite side to that of the Washer Dryer, in such a way that a full opening of the Washer Dryer door is restricted.
- New hoses supplied with the appliance must be used, old hoses must not be reused to avoid danger.
- Do not clean your Washer Dryer with flammable substances or liquids.
- **WARNING:** Never stop the Washer Dryer before the end of the drying cycle, unless all items are removed quickly and spread so that the heat dissipates.
- Remove all items from pockets such as matches and lighters.

## SAVE THESE INSTRUCTIONS



This is the “Read the instructions” symbol.

## IMPORTANT SAFETY INSTRUCTIONS

- Items such as foam rubber (latex foam), shower caps, waterproof textiles, rubber backed articles and clothes or pillows fitted with foam rubber pads should not be dried in the Washer Dryer.
- Do not use this Washer Dryer if industrial chemicals have been used for cleaning. The possible presence of residual quantities of aggressive or decomposed chemicals in the load may produce damage to the Washer Dryer and harmful fumes.
- Do not allow lint to accumulate on rubber bellow, inside drum, or around the dryer.
- Do not dry unwashed items in the Washer Dryer.
- Items that have been soiled with substances such as cooking oil, acetone, alcohol, petrol, kerosene, spot removers, turpentine, waxes and wax removers should be washed in hot water with an extra amount of detergent before being dried in the Washer Dryer. Fabric softeners, or similar products, should be used as specified by the fabric softener instructions.
- The final part of a drying cycle occurs without heat (cool down cycle) to ensure that the articles are left at a temperature that ensures that the items will not be damaged.
- The appliance must be connected to water pressure of 0.03-0.7 MPa.
- This appliance is intended to be used in household and similar applications such as: Staff kitchen areas in shops, offices, and other working environments; Farm houses; By clients in hotels, motels, and other residential-type environments; Bed and breakfast-type environments; Areas for communal use in blocks of flats or in launderettes.
- Bottom opening must not be obstructed by a carpet.
- **WARNING:** The appliance must not be supplied through an external switching device, such as a timer, or connected to a circuit that is regularly switched on and off by a utility.

### SAVE THESE INSTRUCTIONS



This is the “Read the instructions” symbol.

## WARNING



### Electrical Shock Hazard

Plug into a grounded 3 prong outlet.

Do not remove ground prong.

Do not use an adapter.

Do not use an extension cord.

Failure to follow these instructions can result in death, fire, or electrical shock.

## WARNING

### Excessive Weight Hazard

Use two or more people to move and install or uninstall appliance.

Failure to do so can result in back or other injury.

# ADDING LAUNDRY PRODUCTS

## Adding HE detergent to basket:

Single-dose laundry packets, Oxytype boosters, color-safe bleach, or scented crystals can be added to the drum prior to adding laundry. When using single-dose laundry packets, make sure that the Load & Go™ Bulk Dispenser option is disabled.

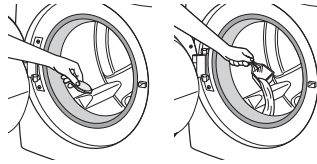

**NOTE:** Follow the manufacturer's instructions to determine the amount of laundry products to use.

## Adding liquid chlorine bleach to single-load dispenser:

Add liquid chlorine bleach to the bleach compartment. Do not overfill, dilute, or use more than 2/3 cup (165 mL). Do not use color-safe bleach or Oxi in the same cycle with liquid chlorine bleach.

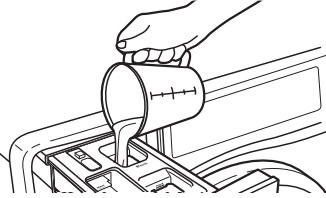

### IMPORTANT:

- Always measure liquid chlorine bleach. Use a measuring cup with a pour spout; do not guess.
- Do not fill beyond the "MAX" line. Overfilling could cause garment damage.
- Do not use thickened, easy-pour, or no-splash bleach when running the Clean Washer with affresh® cycle, as excess suds may occur.
- Do not add liquid chlorine bleach to the bulk dispenser.
- Slowly close dispenser drawers. Make sure the drawers are closed completely.

## Adding liquid fabric softener to single-load dispenser:

Pour a measured amount of liquid fabric softener into liquid fabric softener compartment. Always follow manufacturer's directions for correct amount of fabric softener, based on your load size. Fabric softener is always dispensed in the last rinse.

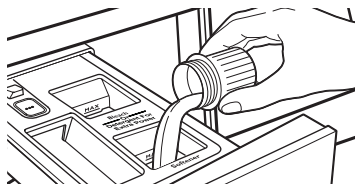

**IMPORTANT:** Do not overfill, dilute, or use more than the manufacturer-recommended quantity of fabric softener. Do not fill past the "MAX" line. Overfilling dispenser will cause fabric softener to immediately dispense into machine.

- Do not spill or drip any fabric softener onto the clothes.
- Do not use liquid fabric softener dispenser balls in this machine. They will not dispense correctly.
- Do not use fabric softener sheets, as they can stain the load.

## Adding HE detergent to Load & Go™ dispenser:

Use only High Efficiency (HE) liquid detergents. The bulk dispensers will hold about 67.6 oz. (2 L) of liquid HE detergent, depending on dispenser, or enough for many loads of laundry.

## To fill bulk dispensers:

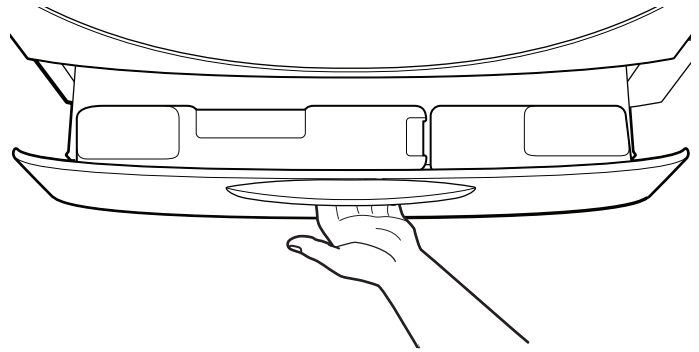

Open the dispenser drawer by pulling on the handle at the base of the machine. If desired, the drawer can be completely removed from the machine.

Locate the Load & Go™ bulk dispenser. Gently pull up on the tab located on the bulk dispenser lid to lift the fill door.

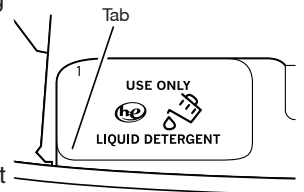

Fill to the "MAX" line (see illustrations at right) with HE liquid detergent. Close fill door. It will click into place. Make sure the concentration setting is correct. (see the Cycle Guide)

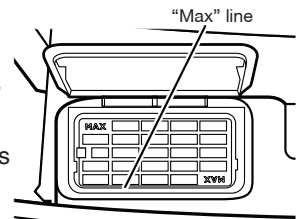

It is recommended that you rinse out the Load & Go™ containers when refilling, when changing detergent types or concentrations, or when they will not be used for an extended period. For instructions on cleaning the dispenser cartridge, see "All-In-One Washer Dryer Maintenance and Care" section.

When you want the machine to use the Load & Go bulk dispenser for automatic detergent dispensing, make sure that the Load & Go™ bulk dispenser option is enabled. Also, do not add any detergent to the single-load dispenser.

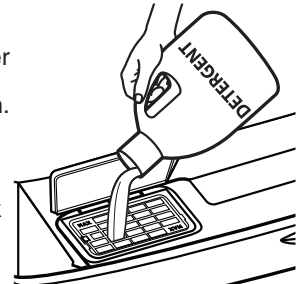

## Adding HE detergent to single-load dispenser:

Pour a measured amount of HE detergent into detergent compartment. For powdered detergent, lift the selector to the high position. For liquid detergent, push down the selector to the low position. Do not overfill; adding too much detergent may cause detergent to be dispensed into the machine too early. When using single-dose dispenser for detergent, make sure that the Load & Go™ bulk dispenser option is disabled.

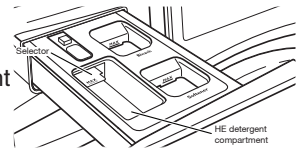

## Getting the most out of your All-In-One Washer Dryer:

Your new machine is configured to run wash cycles by default. You also have the option to run Wash & Dry cycles or Dry Only cycles.

For optimal drying results and to avoid wrinkling of clothes, do not load clothes more than half full. Since this unit uses a ventless drying technology, expect longer dry times compared to a vented Washer Dryer.

# ALL-IN-ONE WASHER DRYER MAINTENANCE AND CARE

## Water Inlet Hoses

Replace inlet hoses after five years of use to reduce the risk of hose failure. Periodically inspect and replace inlet hoses if bulges, kinks, cuts, wear, or leaks are found.

When replacing your inlet hoses:

Mark the date of replacement on the label with a permanent marker.

Check that the old rubber seals on water inlet hoses are not stuck on the machine inlet valves.

Use new washers in the new inlet hoses to ensure a proper seal.

## All-In-One Washer Dryer Care

### Recommendations to Help Keep Your Machine Clean and Performing at Its Best

5. Always use High Efficiency (HE) detergents and follow the HE detergent manufacturer's instructions regarding the amount of HE detergent to use. Do not use more than the recommended amount because that may increase the rate at which detergent and soil residue accumulate inside your machine which, in turn, may result in undesirable odor.
6. Use warm or hot water washes sometimes (not exclusively cold water washes) because they do a better job of controlling the rate at which soils and detergent accumulate.
7. Always leave the machine door slightly ajar between uses to help dry out the machine and avoid the buildup of odor causing residue.
8. Periodically clean residue from all interior surfaces of the window. For better care, wipe the entire inside of the door with a damp cloth.

### Cleaning Your All-In-One Washer Dryer

Read these instructions completely before beginning the routine cleaning processes recommended below. This machine maintenance procedure should be performed, at a minimum, once per month or every 30 cycles, whichever occurs sooner, to control the rate at which soils and detergent may otherwise accumulate in your machine. Note that since this is an all-in-one Washer Dryer without a lint screen, you may see some more lint accumulation on the door seal than a typical washer.

#### Cleaning the Door Seal

1. Open the machine door and remove any clothing or items from the machine.
2. Inspect the gray-colored seal between the door opening and the drum for stained areas, soil buildup, or lint. Pull back the seal to inspect all areas under the seal and to check for foreign objects or lint.
3. If stained areas, soil buildup, or lint are found, wipe down these areas of the seal using either of the following two procedures:
  - a. Affresh® Machine Cleaning Wipes Procedure:
    - i. When the cycle is complete, gently pull back the rubber door seal and clean the entire surface with the textured side of an affresh® Machine Cleaning Wipe.
  - b. Dilute Liquid Chlorine Bleach Procedure:
    - i. Mix a dilute bleach solution, using 3/4 cup (177 mL) of liquid chlorine bleach and 1 gallon (3.8 L) of warm tap water.
    - ii. Wipe the seal area with the dilute solution, using a damp cloth.
    - iii. Let stand for 5 minutes.
    - iv. Wipe down area thoroughly with a dry cloth and let machine interior air dry with door open.

#### IMPORTANT:

- Wear rubber gloves when cleaning with bleach.
- Refer to the bleach manufacturer's instructions for proper use.

#### Cleaning the Inside of the All-In-One Washer Dryer

This machine has a special cycle that uses higher water volumes in combination with affresh® Washer Cleaner or regular liquid chlorine bleach to thoroughly clean the inside of the machine. Steam models also utilize steam to enhance cleaning in this special cycle.

**IMPORTANT:** Do not use thickened, easy-pour, or no-splash bleach when running the Clean Washer with affresh® cycle as excess suds may occur.

**NOTE:** Read these instructions completely before beginning the cleaning process.

#### Begin procedure

1. Clean Washer with affresh® Cycle Procedure (Recommended for best performance):
  - a. Open the machine door and remove any clothing or items.
  - b. Use an affresh® Machine Cleaning Wipe or a soft, damp cloth or sponge to clean the inside door window.
  - c. Add an affresh® Washer Cleaner tablet to the machine drum.
  - d. Do not add the affresh® Washer Cleaner tablet to the dispenser drawer.
  - e. Do not add any detergent or other chemical to the machine when following this procedure.
  - f. Close the machine door.
  - g. Select the Clean Washer with affresh® cycle.
  - h. Select the FanFresh® option to help dry the machine interior after the cycle is complete.

**NOTE:** The machine remembers your last option selection and will use it for future wash cycles until you deselect that option.

- i. Touch and hold START/PAUSE to begin the cycle. The Clean Washer with affresh® cycle operation is described below.
  2. Chlorine Bleach Procedure:
    - a. Open the machine door and remove any clothing or items.
    - b. Open the single load dispenser drawer and add regular liquid chlorine bleach to the "MAX" line in both the bleach compartment and the fabric softener compartment. Either traditional or HE chlorine bleach can be used.
- IMPORTANT:** Do not use thickened, easy-pour, or no splash bleach as excess suds may occur.
- NOTE:** Use of more liquid chlorine bleach than is recommended above could cause machine damage over time.
- c. Close the machine door and the dispenser drawer.
  - d. Do not add any detergent or other chemicals to the machine when following this procedure.
  - e. Select the Clean Washer with affresh® cycle.
  - f. Select the FanFresh® option to help dry the machine interior after the cycle is complete.

**NOTE:** The machine remembers your last option selection and will use it for future wash cycles until you deselect that option.

- g. Touch and hold START/PAUSE to begin the cycle. The Clean Washer with affresh® cycle operation is described below.

**NOTE:** For best results, do not interrupt cycle.

### Description of Clean Washer with affresh® Cycle Operation:

1. The Clean Washer with affresh® cycle will determine whether clothing or other items are in the machine.
2. If no items are detected in the machine, it will proceed with the cycle.
  - a. If any items are detected in the machine, "rL" (remove load) will be displayed. The door will unlock. Open machine and remove any garments from the machine drum.
  - b. Touch POWER to clear the "rL" code.
  - c. Touch and hold START/PAUSE to restart the cycle.
3. Steam models only: During the first 20 minutes of the cycle, it will activate the steamer but the drum will not spin or fill with water. You may see condensation on the door window during this initial phase. If you are using an affresh® Washer Cleaner tablet, it will not dissolve completely during the steam phase. This is normal.
4. After the cycle is complete, leave the door open slightly to allow for better ventilation and drying of the machine interior.

### Cleaning the Dispensers

After using the Clean Washer with affresh® cycle, you may find some residue buildup in the machine's dispensers.

To remove residue from the single load dispenser, remove the drawer and wipe the surfaces with an affresh® Machine Cleaning Wipe or a damp cloth and towel dry either before or after you run the Clean Washer with affresh® cycle. Use an all-purpose surface cleaner, if needed.

To remove residue from the Load & Go™ bulk dispenser, lift the handle on the dispenser housing and pull to remove it from the machine cabinet; then rinse the dispenser thoroughly with running water. Wipe the outside dispenser surface with an affresh® Machine Cleaning Wipe or a damp cloth, and towel dry. Use an all-purpose surface cleaner, if needed.

Replace the dispenser in the machine cabinet and make sure that it is correctly seated.

**NOTE:** Dispensers are not dishwasher-safe.

### Cleaning the Outside of the All-In-One Washer Dryer

Use an affresh® Machine Cleaning Wipe or a soft, damp cloth or sponge to wipe up any spills. Occasionally wipe the outside of your machine to help keep it looking new. Use an affresh® Machine Cleaning Wipe or mild soap and water.

**IMPORTANT:** To avoid damaging the machine's finish, do not use abrasive products.

### Clean Washer Cycle Reminder

**NOTE:** Not all models have the Clean Washer with affresh® cycle reminder light.

The Clean Washer with affresh® LED "cL" will flash at the end of a wash cycle when the machine has run 30 wash cycles. This is a reminder to run the Clean Washer with affresh® cycle.

If the Clean Washer with affresh® cycle is not performed, the LED will stop flashing at the end of a wash cycle after running three more regular wash cycles. After 30 more wash cycles are completed, the Clean Washer with affresh® LED will again flash at the end of a wash cycle as a reminder.

### Removing The Dispenser

#### Single Load Dispenser Drawer

##### To remove:

1. Pull dispenser drawer out until it stops.
2. Press down on the release tab and pull straight out to remove the dispenser.

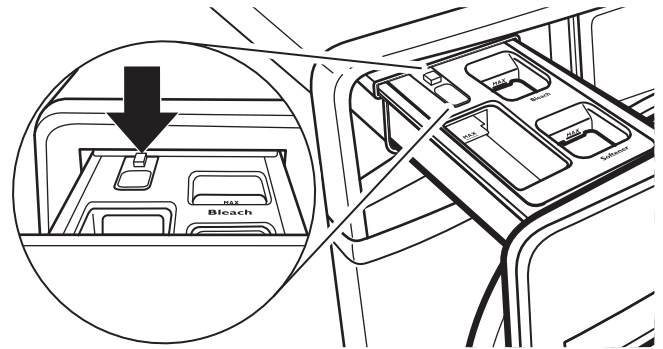

3. Lift off cover panel by pulling straight up.

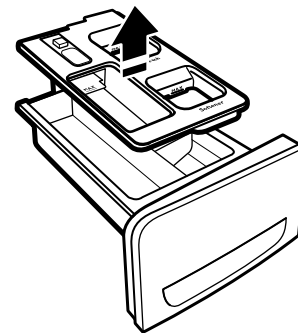

##### To replace:

1. Position cover panel back onto posts on dispenser. Apply slight pressure on cover panel to seat it.
2. Align edges of dispenser with guides in machine; then slide dispenser back into slot.

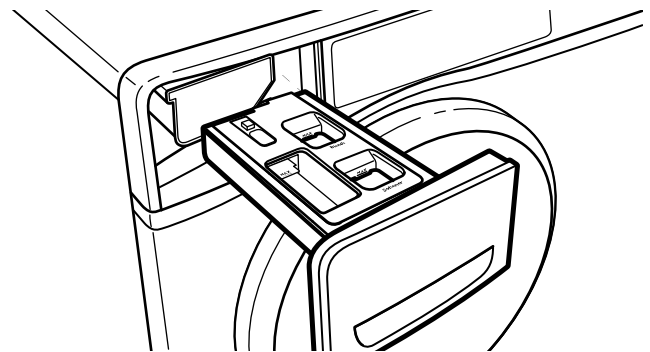

### Cleaning Load & Go™ Containers

It is recommended that you rinse out the Load & Go™ containers when refilling, when changing detergent types or concentrations, or when the machine will not be used for an extended period.

1. Pull the dispenser drawer out until it stops.
2. Lift out the Load & Go™ containers.

- Lift the fill lid and flush interior thoroughly with warm water.

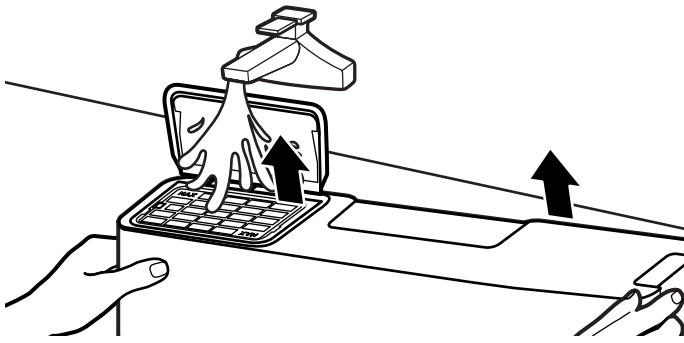

- Allow to air dry.

### Non-Use and Vacation Care

Operate your machine only when you are home. If moving or not using your machine for a period of time, follow these steps:

- Unplug or disconnect power to machine.
- Turn off water supply to machine to avoid flooding due to water pressure surges.  
**HELPFUL TIP:** Attach a reminder note to the machine to turn the water back on before machine's next use.
- Clean the dispensers. See "Cleaning the Dispensers."

### Winter Storage Care

**IMPORTANT:** To avoid damage, install and store machine where it will not freeze. Because some water may stay in hoses, freezing can damage machine. If storing or moving during freezing weather, winterize your machine.

#### To winterize machine:

- Shut off both water faucets; then disconnect and drain water inlet hoses.  
**HELPFUL TIP:** Attach a reminder note to the machine to turn the water back on before machine's next use.
- Put 1 quart (1 L) of R.V.-type antifreeze in machine drum and run machine on Normal cycle for about 2 minutes to mix antifreeze and remaining water.
- Unplug machine or disconnect power.

### Transporting your All-In-One Washer Dryer

- Shut off both water faucets. Disconnect and drain water inlet hoses.
- If machine will be moved during freezing weather, follow "Winter Storage Care" directions before moving.
- Disconnect drain hose from drain system and from back of machine.
- Unplug power cord.
- Place inlet hoses and drain hose inside machine drum.
- Bundle power cord with a rubber band or cable tie to keep it from hanging to the ground.  
**IMPORTANT:** Call for service to install new transport bolts. Do not reuse transport bolts. Machine must be transported in the upright position. To avoid structural damage to your machine, it must be properly set up for relocation by a certified technician.

## ⚠ WARNING



### Electrical Shock Hazard

Plug into a grounded 3 prong outlet.

Do not remove ground prong.

Do not use an adapter.

Do not use an extension cord.

**Failure to follow these instructions can result in death, fire, or electrical shock.**

### Reinstalling/Using Again

To reinstall machine after non-use, vacation, winter storage, or moving:

- Refer to Installation Instructions to remove transport bolts, locate, level, and connect machine.
- Before using again, run machine through the following recommended procedure:

#### To use machine again:

- Flush water pipes and hoses. Reconnect water inlet hoses. Turn on both water faucets.
- Plug in machine or reconnect power.
- Run machine through Heavy Duty cycle to clean machine and remove antifreeze, if used. Use only HE detergent. Use half the manufacturer's recommended amount for a medium-size load.

### Cleaning the Drain Pump Filter/Draining

#### Residual Water

**NOTE:** Perform the following procedure occasionally.

**IMPORTANT:** Make sure the machine is off before cleaning the drain pump filter.

- Open the dispenser drawer by pulling on the handle at the base of the machine. This will reveal the drain pump filter. Remove the drawer by releasing the tab on each side. With your finger, push down on tab on right side of drawer, and up on tab on left side of drawer.

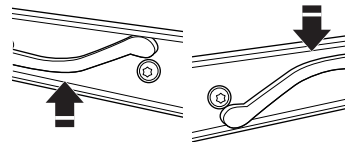

Left side

Right side

- Place a broad, flat container beneath the drain pump filter to collect the drain water. Release the black hose from the hose clip, remove the plug, and drain the hose into the container. Empty the container. Repeat this procedure if necessary until all the water has drained. Make sure that the black hose is completely dry, replace the plug, and secure the hose in the clip.

**NOTE:** If water does not drain well, push in hose slightly to remove any possible kinks.

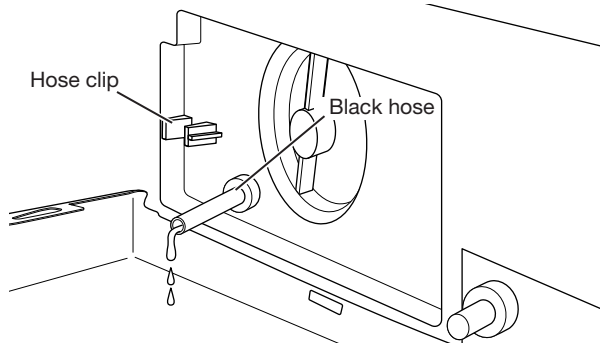

- Lay a cotton cloth beneath the drain pump filter to absorb any water still in it. Then remove the drain pump filter by turning it counterclockwise.

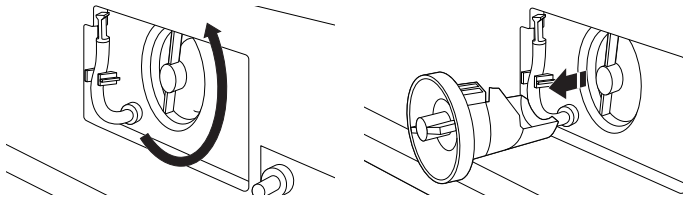

- Check the drain pump filter once a month. Remove large clumps of lint by hand from the filter and place lint in a suitable waste container. Remove remaining residue from the filter by rinsing with water.

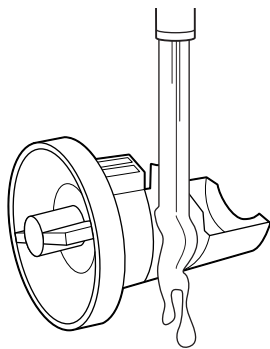

- Reinsert the drain pump filter by turning it clockwise. Make sure to turn it in as far as it will go, with the filter handle remaining as close as possible to the vertical position.

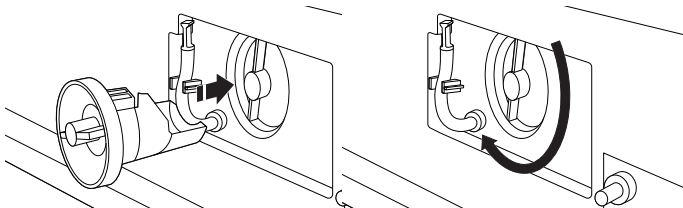

- Replace and close the dispenser drawer. Make sure to insert both rails simultaneously when replacing the drawer. You will hear a clicking sound that indicates the rails have engaged. To ensure proper placement of the drawer, pull out fully. The drawer should be fully engaged and the rails locked in place. Make sure the drain hose is secured in the hose clip and tucked underneath the cutout.

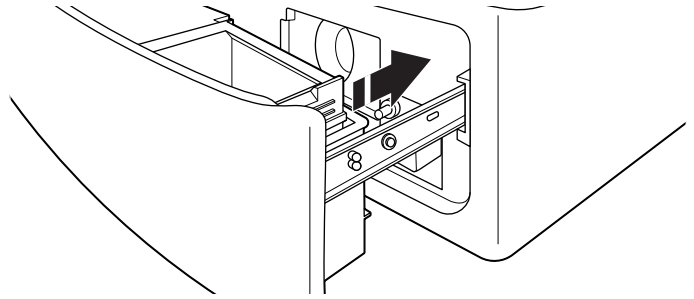

### Additional Cleaning

Gently pull back the rubber door seal and clean any stained areas, soil buildup, or lint with the textured side of an affresh® Machine Cleaning Wipe.

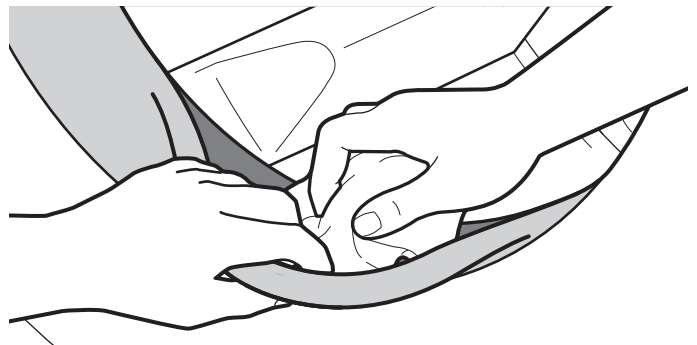

## INSTALLATION INSTRUCTIONS

### ⚠ WARNING

#### Excessive Weight Hazard

Use two or more people to move and install or uninstall appliance.

Failure to do so can result in back or other injury.

**NOTE:** To avoid floor damage, set machine onto cardboard before moving it.

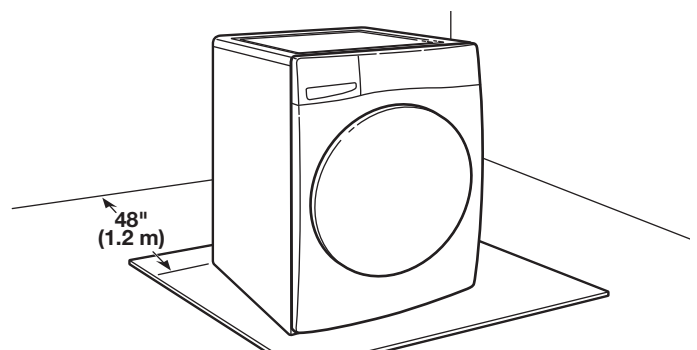

### Move All-In-One Washer Dryer

It is necessary to remove all shipping materials for proper operation and to avoid excessive noise from machine.

Move machine to within 4 ft (1.2 m) of its final location. It must be in a fully upright position.



## Locate transport bolts

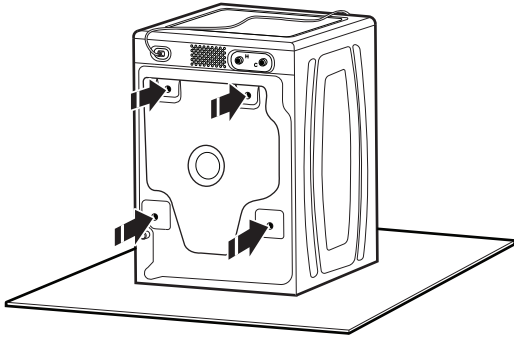

Locate four transport bolts on rear of machine.

## Remove transport bolts from All-In-One Washer Dryer

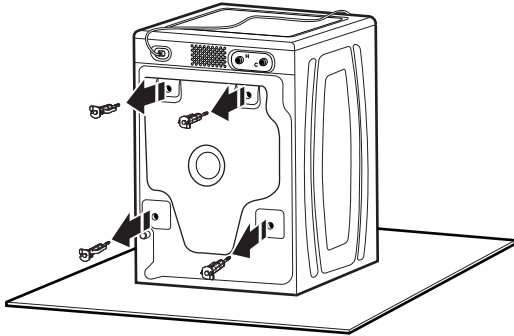

Loosen bolts with a 5/8" (16 mm) wrench.

Remove each bolt from machine, by pulling in the direction of the arrows, pull bolts and plastic spacers from back of machine. Discard bolts and spacers.

**NOTE:** Do not plug machine in until installation has been completed.

# REQUIREMENTS

## Tools and Parts

### Tools and Parts

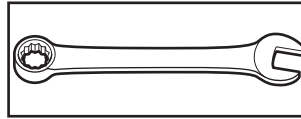

Adjustable or open end wrenches 1/2" (13 mm), 5/8" (16 mm) and 9/16" (14 mm)

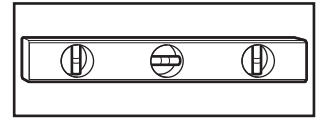

Level

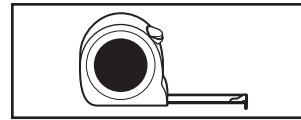

Ruler or measuring tape

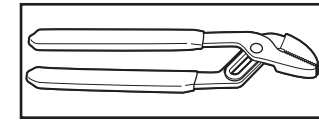

Pliers that open to 1<sup>9</sup>/<sub>16</sub>" (39.5 mm)

### Optional tool

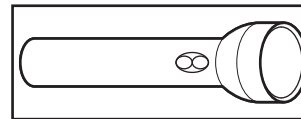

Flashlight

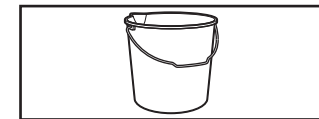

Bucket

### Parts supplied with machine

**NOTE:** All parts supplied for installation are in the machine basket.

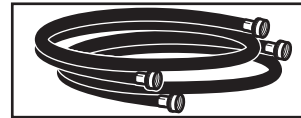

Water inlet hoses (2)

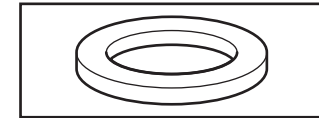

Flat inlet hose washers (4)

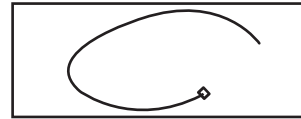

Cable tie



Drain hose with clamp and form (may be shipped unassembled)

### Available accessories:

An optional matching pedestal is available for your machine. Please contact your retailer for ordering information, or see the "Assistance or Service" on Quick Start Guide.

### Alternate parts (not supplied with machine):

Your installation may require additional parts. To order, please refer to toll-free numbers on Quick Start Guide.

#### If you have:

Overhead sewer

#### You will need:

Standard 20 gallon (76 L) 39" (990 mm) tall drain tub or utility sink, sump pump and connectors (available from local plumbing suppliers)

## Location Requirements

Proper installation is your responsibility.

### You will need:

- A water heater set to 120°F (49°C).
- A grounded electrical outlet located within 6 ft (1.8 m) of power cord on back of machine.
- Hot and cold water faucets located within 4 ft (1.2 m) of hot and cold water fill valves on machine, and water pressure of 0.03-0.7 MPa.
- A level floor with maximum slope of 1" (25 mm) under entire machine. Installing on carpet or surfaces with foam backing is not recommended.
- Floor must support machine's total weight (with water and load) of 315 lb (143 kg).

**IMPORTANT:** Do not install, store, or operate machine where it will be exposed to weather or in temperatures below 32°F (0°C). Water remaining in machine after use may cause damage in low temperatures. See "All-In-One Washer Dryer Care" for winterizing information.

### Whirlpool® Models\*

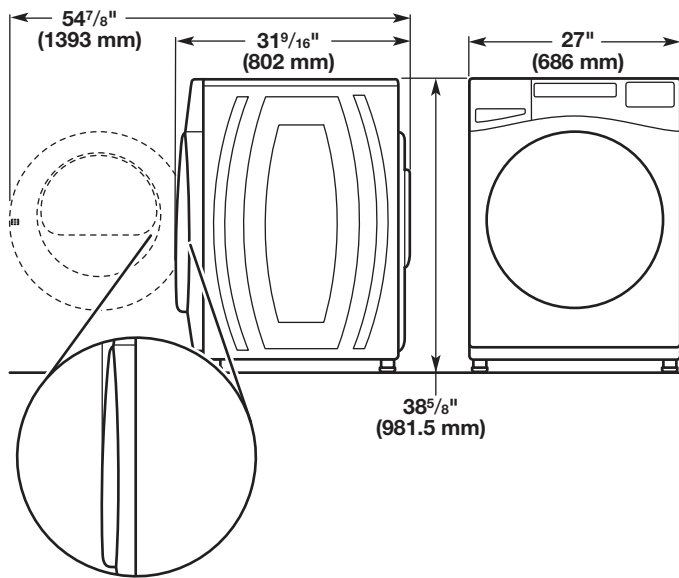

\*For additional details (or information) specific to your model, refer to the 'Dimensions' listed for your model at [www.whirlpool.com.tw](http://www.whirlpool.com.tw).

### Custom under-counter installation:

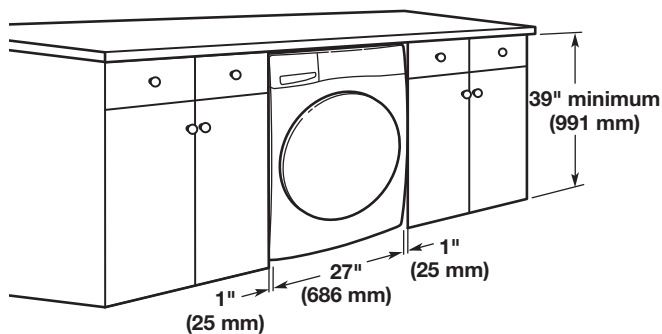

### Recessed area or closet installation:

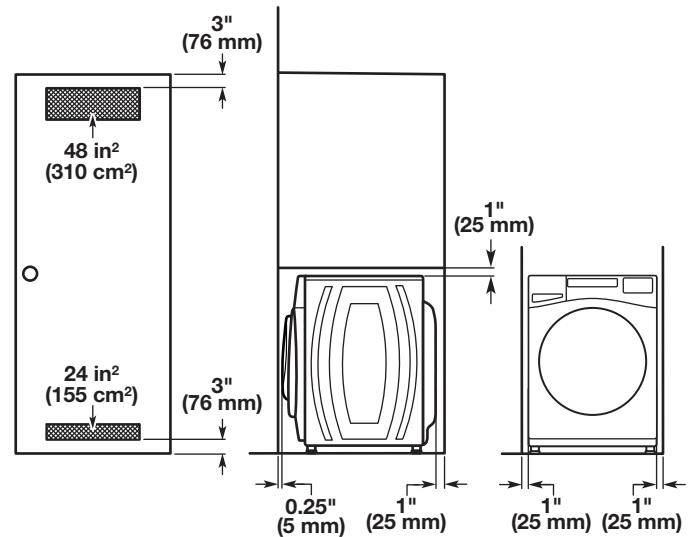

### Custom cabinet installation:

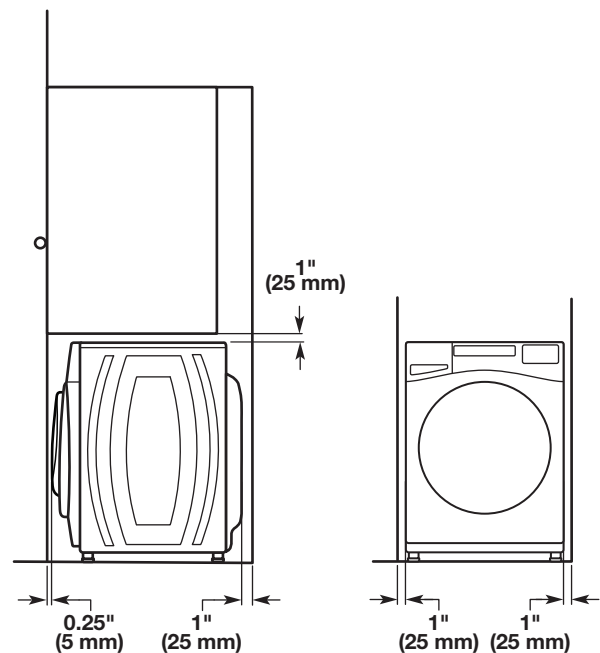

## Drain System

The drain system can be installed using a floor drain, wall standpipe, or laundry tub. Select the method you need.

**IMPORTANT:** To avoid siphoning, no more than 4.5" (114 mm) of drain hose should be inside standpipe or below the top of wash tub. Secure drain hose with cable tie.

### Floor standpipe drain system

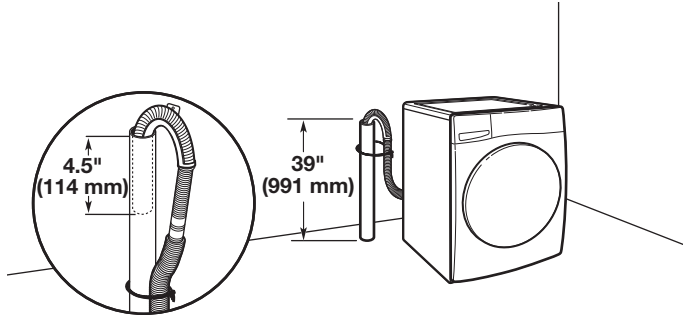

Minimum diameter for a standpipe drain: 2" (51 mm). Minimum carry-away capacity: 17 gallon (64 L) per minute. A 1/4" (6 mm) diameter to 1" (25 mm) diameter Standpipe Adapter Kit is available (Part Number 3363920). Top of standpipe must be at least 39" (991 mm) from the floor; install no higher than 96" (2.44 m) from bottom of machine. If you have an overhead sewer and need to pump higher than 96" (2.44 m), a sump pump and associated hardware are needed. See "Alternate parts."

### Wall standpipe drain system

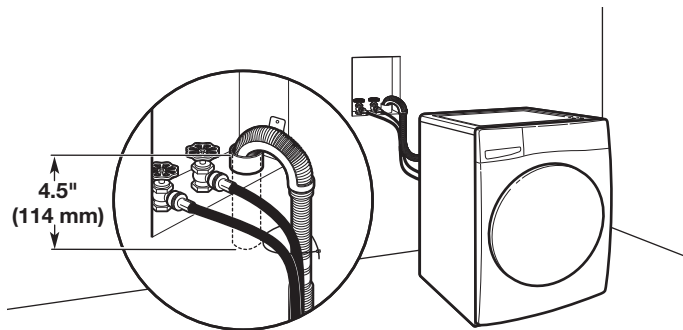

See requirements in the "Floor standpipe drain system" section.

### Laundry tub drain system

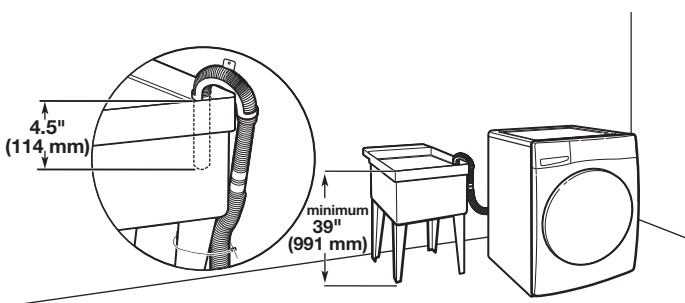

Minimum capacity: 20 gallon (76 L). Top of laundry tub must be at least 39" (991 mm) from the floor; install no higher than 96" (2.44 m) from bottom of machine.

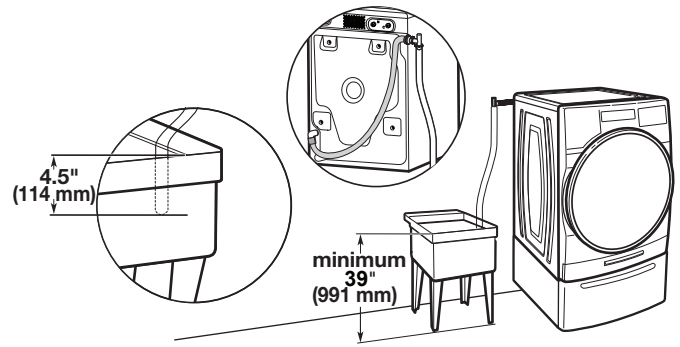

### Floor Drain System

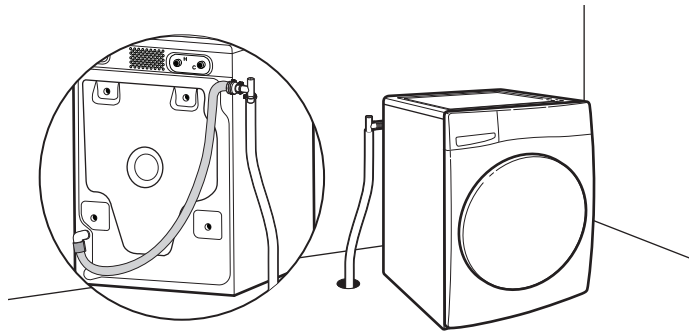

Floor drain system requires a Siphon Break Kit, two Connector Kits, and an Extension Drain Hose that may be purchased separately. Please contact your retailer for ordering information, or see the "Assistance or Service" on Quick Start Guide. Minimum siphon break height: 28" (710 mm) from bottom of machine. (Additional hoses may be needed.)

## Electrical Requirements

### ⚠ WARNING



#### Electrical Shock Hazard

**Plug into a grounded 3 prong outlet.**

**Do not remove ground prong.**

**Do not use an adapter.**

**Do not use an extension cord.**

**Failure to follow these instructions can result in death, fire, or electrical shock.**

- A 120 V, 60 Hz, AC only, 15 A or 20 A, fused electrical supply is required. A time-delay fuse or circuit breaker is recommended. It is recommended that a separate circuit breaker serving only this appliance be provided.
- This machine is equipped with a power supply cord having a 3 prong grounding plug.
- To minimize possible shock, the cord must be plugged into a mating, 3 prong grounding-type outlet, grounded in accordance with local codes and ordinances. If a mating outlet is not available, it is the personal responsibility and obligation of the customer to have the properly grounded outlet installed by a qualified electrician.
- If codes permit and a separate ground wire is used, it is recommended that a qualified electrician determine that the

ground path is adequate.

- Do not ground to a gas pipe.
- Check with a qualified electrician if you are not sure the machine is properly grounded.
- Do not have a fuse in the neutral or ground circuit.

### GROUNDING INSTRUCTIONS

#### For a grounded, cord-connected appliance:

This appliance must be grounded. In the event of a malfunction or breakdown, grounding will reduce the risk of electric shock by providing a path of least resistance for electric current. This appliance is equipped with a cord having an equipment-grounding conductor and a grounding plug. The plug must be plugged into an appropriate outlet that is properly installed and grounded in accordance with all local codes and ordinances.

**WARNING:** Improper connection of the equipment grounding conductor can result in a risk of electric shock. Check with a qualified electrician or serviceman if you are in doubt as to whether the appliance is properly grounded. Do not modify the plug provided with the appliance: if it will not fit the outlet, have a proper outlet installed by a qualified electrician.

**SAVE THESE INSTRUCTIONS**

## INSTALLATION

### Connect Drain Hose

#### Attach drain hose to drain port

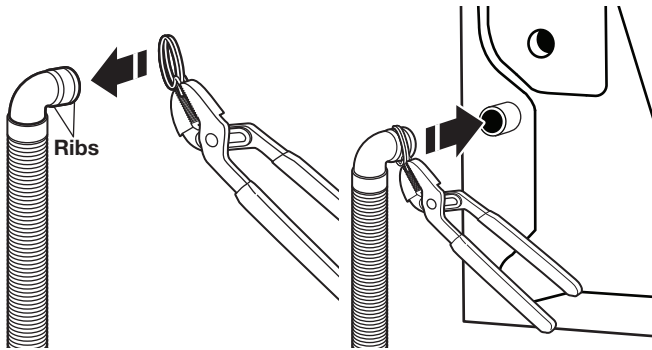

If clamp is not already in place on elbow end of drain hose, squeeze clamp with pliers and slide it over end of hose, centering it between the ribs, as shown. Squeeze clamp with pliers and slide elbow end of drain hose onto drain port and secure with clamp.

For a laundry tub or standpipe drain, refer the above/below steps.

For a floor drain, remove the preinstalled drain hose form as shown in the steps above/below. You may need additional parts with separate directions. See "Alternate Parts."

It is the responsibility of the installer to install and secure the drain hose into the provided plumbing/drain in a manner that will avoid the drain hose coming out of or leaking from the plumbing/drain.

#### Remove drain hose form (floor drain installations only)

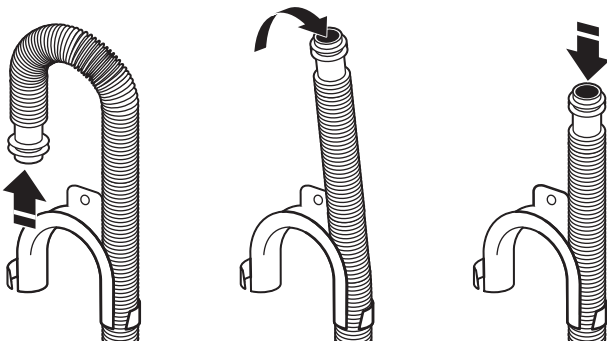

For floor drain installations, you will need to remove the drain hose form from the end of the drain hose. You may need additional parts with separate directions. See "Alternate Parts."

#### Place drain hose in standpipe

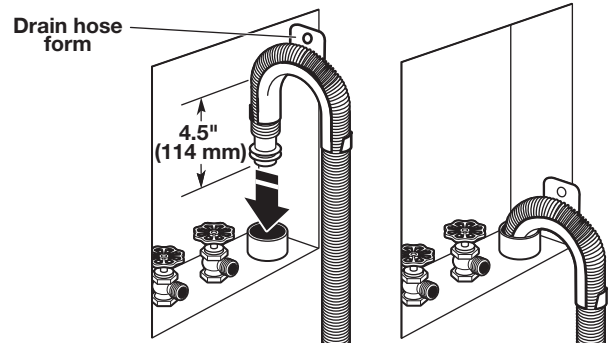

Place hose into standpipe (shown in picture) or over side of laundry tub.

**IMPORTANT:** 4.5" (114 mm) of drain hose should be inside standpipe; do not force excess hose into standpipe or lay on bottom of laundry tub. Drain hose form must be used.

### Connect Inlet Hose

#### Insert new flat washers

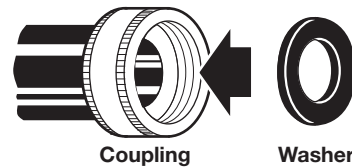

**IMPORTANT:** To avoid leaks, check that your water inlet hoses have flat washers at both ends. Machine must be connected to water faucets with new inlet hoses with flat washers. Do not use old hoses. Do not use hoses without washers.

#### Connect inlet hoses to water faucets

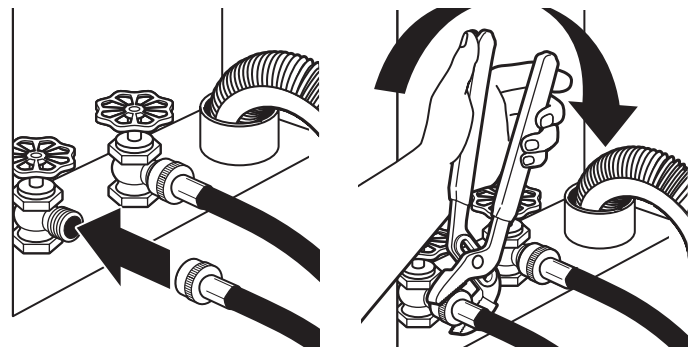

**IMPORTANT:** Do not overtighten or use tape or sealants on valve when attaching to faucets or machine. Damage can result. Attach the hose labeled hot to hot water faucet. Screw on coupling by hand until it is seated on washer. Use adjustable pliers to tighten couplings an additional two-thirds turn. Repeat this step with the hose labeled cold for the cold water faucet. Both hoses must be connected for machine to work properly.

#### Clear water lines

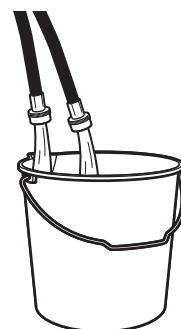

Run water for a few seconds through hoses into a laundry tub, drainpipe, or bucket to avoid clogs. Water should run until clear.

### Connect inlet hoses to Machine

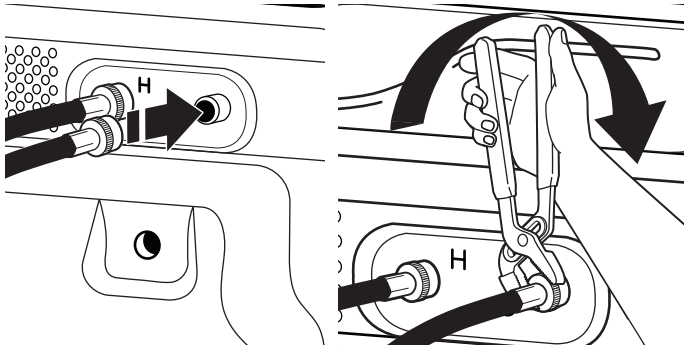

**IMPORTANT:** To reduce risk of hose failure, replace the hoses every 5 years. Record hose installation or replacement dates for future reference.

- Do not overtighten hose or use tape or sealants on the valve. Damage to the valves can result.
- Periodically inspect and replace hoses if bulges, kinks, cuts, wear, or leaks are found.

Attach hot water hose to hot water inlet valve. Screw coupling by hand until it is snug. Use adjustable pliers to tighten couplings an additional two-thirds turn. Repeat with cold water inlet valve.

### Check for leaks

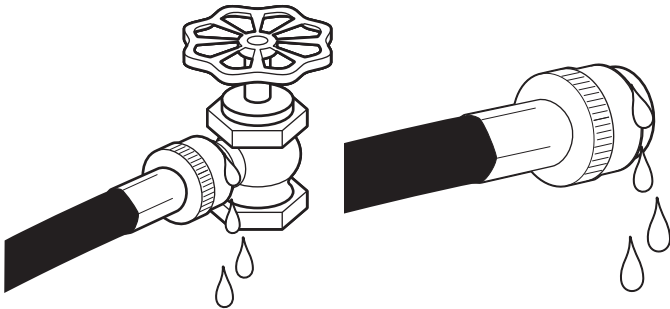

Slowly turn on water faucets to check for leaks. A small amount of water may enter machine. It will drain later.

### Secure drain hose

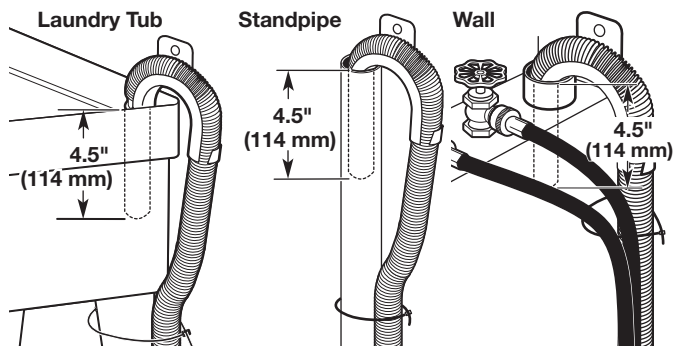

Secure drain hose to laundry tub leg, drain standpipe, or inlet hoses for wall standpipe with cable tie or beaded tie strap. It is the responsibility of the installer to install and secure the drain hose in to the provided plumbing/drain in a manner that will avoid the drain hose coming out of or leaking from the plumbing/drain.

## Level All-In-One Washer Dryer

**IMPORTANT:** Leveling your machine properly reduces excess noise and vibration.

### Check levelness of machine

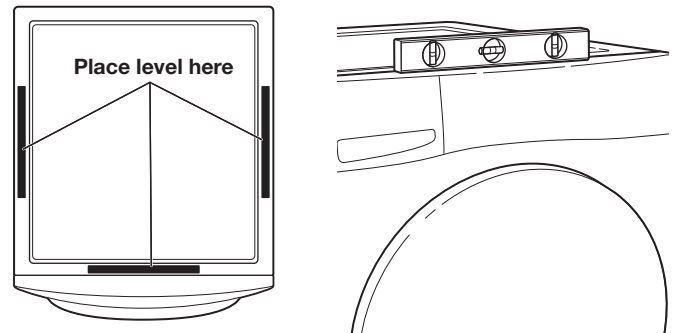

Remove cardboard from beneath machine. Place a level on top edges of machine, checking each side and front. If not level, tip machine and adjust feet up or down as shown in "Adjust leveling feet" and "Tighten leveling feet", repeating as necessary.

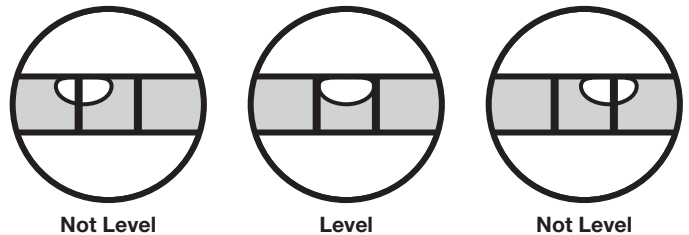

### Rock machine to test foot contact

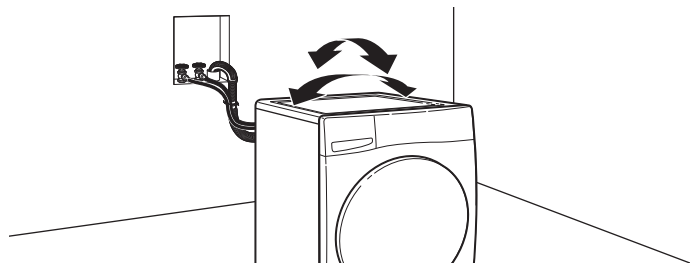

Grip machine from top and rock back and forth, making sure all four feet are firmly on floor. Repeat, rocking machine from side to side. If machine rocks, adjust leveling feet. If all four feet are in firm contact with floor, tighten leveling feet.

### Adjust leveling feet

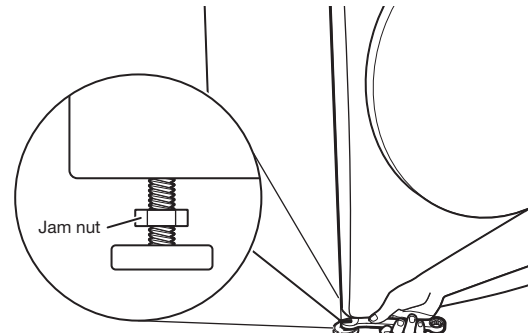

If machine is not level, use a 9/16" (14 mm) open-end or adjustable wrench to turn jam nuts clockwise on feet until they are about 1/2" (13 mm) from the machine cabinet. Then turn the leveling foot clockwise to lower the machine or counterclockwise to raise the machine. Do not exceed 2" (50 mm) from bottom of foot to bottom of cabinet. Recheck levelness of machine and that all four feet are firmly in contact with the floor. Repeat as needed.

**HELPFUL TIP:** You may want to prop up front of machine about 4" (102 mm) with a wood block or similar object that will support weight of machine.

### Tighten leveling feet

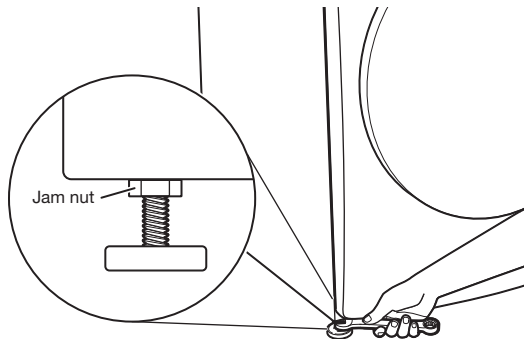

When machine is level and all four feet are firmly in contact with the floor, use a 9/16" (14 mm) open-end or adjustable wrench to turn jam nuts counterclockwise on leveling feet tightly against machine cabinet.

**HELPFUL TIP:** You may want to prop machine with wooden block.

## ⚠ WARNING



### Electrical Shock Hazard

**Plug into a grounded 3 prong outlet.**

**Do not remove ground prong.**

**Do not use an adapter.**

**Do not use an extension cord.**

**Failure to follow these instructions can result in death, fire, or electrical shock.**

### Plug into a grounded 3 prong outlet

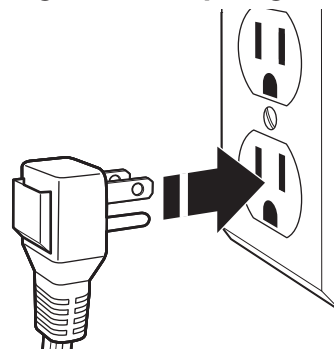

## Complete Installation Checklist

- Check electrical requirements. Be sure you have correct electrical supply and recommended grounding method.
- Check that all parts are now installed. If there is an extra part, go back through steps to see what was skipped.
- Check that you have all of your tools. Check that transport materials were completely removed from back of machine.
- Check that both hot and cold hoses are attached and water faucets are on.
- Check for leaks around faucets, valves, and inlet hoses.
- Remove protective film from console and any tape remaining on machine.
- Check that machine is plugged into a grounded 3 prong outlet.
- Dispose of/recycle all packaging materials.
- To test and clean your machine, press POWER and choose the Quick cycle and run it without clothes. Use only HE detergent. Use 1/2 the manufacturer's recommended amount for a medium-size load.

# ALL-IN-ONE WASHER DRYER CYCLE GUIDE

This All-in-One Washer Dryer has a unique user interface to help you select the best cycle for your load. The “What to Wash” “How to Wash” layout guides you to the optimal cycle in two easy steps:

First determine what items are in the load that you are trying to wash. Use that to guide your “What to Wash” selection. Then determine how you want the Washer Dryer to wash them and select the appropriate “How to Wash” selection. Selecting “What to Wash” will automatically select a default “How to Wash selection” so selecting a “How to Wash” is optional. See chart below for more details.

| What items Do You Want to Wash?   | “What to Wash” Cycle Selection: |
|---|---------------------------------|
| Cottons, linens, and mixed garment loads  | Regular                         |
| No-iron fabrics, dress shirts/pants, synthetics, sheer/lacy garments            | Delicates                       |
| Large items such as small comforters, sleeping bags, jackets, and washable rugs | Bulky Items                     |
| White fabrics/garments  | Whites                          |
| Bright or dark-colored linens and mixed loads                                   | Colors                          |
| Sturdy towels and washcloths  | Towels                          |

| How Do You Want to Wash Them?                      | “How to Wash” Cycle Selection: |
|--|--------------------------------|
| Regular/Normal                                     | Normal                         |
| With fewer wrinkles                                | Wrinkle Control                |
| Intense Cleaning                                   | Heavy Duty                     |
| Eliminate 99.9% of three common household bacteria | Sanitize*                      |
| Gentle cleaning with cold water                    | Cold Wash                      |
| Fast   | Quick                          |

Settings and options shown in bold are default settings for that wash cycle. For best fabric care, choose the cycle, options, and settings that best fit the load being washed. Always read and follow fabric care labels and laundry product instructions. Avoid tightly packing the Washer Dryer. The Washer Dryer will not rinse well or spin correctly if tightly packed. If running Wash & Dry or Dry Only, loading the drum half full or less will optimize drying performance and cycle time. Not all settings are available with each cycle, and some options cannot be used together. Not all options are available on all models.

| What    | How             | Basic Settings                                  |   |                                 | Additional Options |           |             |            |            |
|---------|-----------------|---|---|---------------------------------|--------------------|-----------|-------------|------------|------------|
|         |                 | Temp  | Spin  | Soil                            | Steam Clean        | FanFresh® | Extra Rinse | Wash & Dry | Load & Go™ |
| Regular | Normal          | Hot<br>Very Warm<br><b>Warm</b><br>Cool<br>Cold | <b>Fast</b><br>Medium Fast<br>Medium<br>Off         | Light<br><b>Normal</b><br>Heavy | X                  | X         | X           | X          | <b>X</b>   |
|         | Wrinkle Control | Hot<br>Very Warm<br>Warm<br>Cool<br><b>Cold</b> | Fast<br>Medium Fast<br>Medium<br><b>Slow</b><br>Off | Light<br>Normal<br>Heavy        | X                  | X         | X           | X          | <b>X</b>   |
|         | Heavy Duty      | Hot<br><b>Very Warm</b><br>Warm<br>Cool<br>Cold | <b>Fast</b><br>Medium Fast<br>Medium<br>Off         | Light<br><b>Normal</b><br>Heavy | X                  | X         | X           | X          | <b>X</b>   |

| What      | How                    | Basic Settings                                  |   |                                 | Additional Options |           |             |            |            |
|-----------|------------------------|---|---|---------------------------------|--------------------|-----------|-------------|------------|------------|
|           |                        | Temp  | Spin  | Soil                            | Steam Clean        | FanFresh® | Extra Rinse | Wash & Dry | Load & Go™ |
| Regular   | Sanitize*              | <b>Hot</b>                                      | <b>Fast</b><br>Medium Fast<br>Medium                | <b>Light</b><br>Normal<br>Heavy | X                  | X         | X           | X          | <b>X</b>   |
|           | Cold Wash              | Hot<br>Very Warm<br>Warm<br>Cool<br><b>Cold</b> | <b>Fast</b><br>Medium Fast<br>Medium<br>Off         | Light<br>Normal<br><b>Heavy</b> |                    | X         | X           | X          | <b>X</b>   |
|           | Quick                  | Hot<br>Very Warm<br><b>Warm</b><br>Cool<br>Cold | <b>Fast</b><br>Medium Fast<br>Medium<br>Off         | <b>Light</b><br>Normal<br>Heavy | X                  | X         | X           | X          | <b>X</b>   |
|           | Dry Only               |   |   |                                 |                    | X         |             |            |            |
| Delicates | Normal                 | Hot<br>Very Warm<br><b>Warm</b><br>Cool<br>Cold | Fast<br>Medium Fast<br>Medium<br><b>Slow</b><br>Off | Light<br><b>Normal</b><br>Heavy | X                  | X         | X           | X          | <b>X</b>   |
|           | Quick                  | Hot<br>Very Warm<br><b>Warm</b><br>Cool<br>Cold | Fast<br>Medium Fast<br>Medium<br><b>Slow</b><br>Off | <b>Light</b><br>Normal<br>Heavy | X                  | X         | X           | X          | <b>X</b>   |
|           | <b>Wrinkle Control</b> | Hot<br>Very Warm<br>Warm<br>Cool<br><b>Cold</b> | Fast<br>Medium Fast<br>Medium<br><b>Slow</b><br>Off | <b>Light</b><br>Normal<br>Heavy | X                  | X         | X           | X          | <b>X</b>   |
|           | Dry Only               |   |   |                                 |                    | X         |             |            |            |
|           | Heavy Duty             | Hot<br><b>Very Warm</b><br>Warm<br>Cool<br>Cold | Fast<br>Medium Fast<br>Medium<br><b>Slow</b><br>Off | Light<br><b>Normal</b><br>Heavy | X                  | X         | X           | X          | <b>X</b>   |

\*This cycle eliminates 99.9% of the most common bacteria found in clothes, sheets, and towels. Using the highest wash temperature available ensures sanitization. Check recommended wash temperature of your items. Bacteria tested were K. pneumonia, P. aureginosa, and S. aureus.



| What        | How               | Basic Settings                                  |   |                                 | Additional Options |           |             |            |            |
|-------------|-------------------|---|---|---------------------------------|--------------------|-----------|-------------|------------|------------|
|             |                   | Temp  | Spin  | Soil                            | Steam Clean        | FanFresh® | Extra Rinse | Wash & Dry | Load & Go™ |
| Delicates   | Cold Wash         | Hot<br>Very Warm<br>Warm<br>Cool<br><b>Cold</b> | Fast<br>Medium Fast<br>Medium<br><b>Slow</b><br>Off | Light<br><b>Normal</b><br>Heavy |                    | X         | X           | X          | <b>X</b>   |
|             | Sanitize*         | <b>Hot</b>                                      | <b>Fast</b><br>Medium Fast<br>Medium<br>Slow<br>OFF | <b>Light</b><br>Normal<br>Heavy | X                  | X         | X           | X          | <b>X</b>   |
| Bulky Items | Normal            | Hot<br>Very Warm<br><b>Warm</b><br>Cool<br>Cold | Fast<br><b>Medium Fast</b><br>Medium<br>Slow<br>Off | Light<br><b>Normal</b><br>Heavy | X                  | X         | X           | X          | <b>X</b>   |
|             | Quick             | Hot<br>Very Warm<br><b>Warm</b><br>Cool<br>Cold | Fast<br><b>Medium Fast</b><br>Medium<br>Slow<br>Off | <b>Light</b><br>Normal<br>Heavy | X                  | X         | X           | X          | <b>X</b>   |
|             | Wrinkle Control   | Hot<br>Very Warm<br>Warm<br>Cool<br><b>Cold</b> | Fast<br>Medium Fast<br>Medium<br><b>Slow</b><br>Off | <b>Light</b><br>Normal<br>Heavy | X                  | X         | X           | X          | <b>X</b>   |
|             | <b>Heavy Duty</b> | Hot<br><b>Very Warm</b><br>Warm<br>Cool<br>Cold | Fast<br><b>Medium Fast</b><br>Medium<br>Slow<br>Off | Light<br><b>Normal</b><br>Heavy | X                  | X         | X           | X          | <b>X</b>   |
|             | Dry Only          |   |   |                                 |                    | X         |             |            |            |
|             | Cold Wash         | Hot<br>Very Warm<br>Warm<br>Cool<br><b>Cold</b> | Fast<br><b>Medium Fast</b><br>Medium<br>Slow<br>Off | Light<br><b>Normal</b><br>Heavy |                    | X         | X           | X          | <b>X</b>   |

\*This cycle eliminates 99.9% of the most common bacteria found in clothes, sheets, and towels. Using the highest wash temperature available ensures sanitization. Check recommended wash temperature of your items. Bacteria tested were K. pneumonia, P. aereginosa, and S. aureus.

| What   | How             | Basic Settings                                  |   |                                 | Additional Options |           |             |            |            |
|--------|-----------------|---|---|---------------------------------|--------------------|-----------|-------------|------------|------------|
|        |                 | Temp  | Spin  | Soil                            | Steam Clean        | FanFresh® | Extra Rinse | Wash & Dry | Load & Go™ |
| Whites | Normal          | Hot<br>Very Warm<br><b>Warm</b><br>Cool<br>Cold | Fast<br><b>Medium Fast</b><br>Medium<br>Slow<br>Off | Light<br>Normal<br><b>Heavy</b> | X                  | X         | X           | X          | X          |
|        | Quick           | Hot<br>Very Warm<br><b>Warm</b><br>Cool<br>Cold | Fast<br><b>Medium Fast</b><br>Medium<br>Slow<br>Off | <b>Light</b><br>Normal<br>Heavy | X                  | X         | X           | X          | X          |
|        | Wrinkle Control | Hot<br>Very Warm<br>Warm<br>Cool<br><b>Cold</b> | Fast<br>Medium Fast<br>Medium<br><b>Slow</b><br>Off | <b>Light</b><br>Normal<br>Heavy | X                  | X         | X           | X          | X          |
|        | Heavy Duty      | Hot<br><b>Very Warm</b><br>Warm<br>Cool<br>Cold | Fast<br><b>Medium Fast</b><br>Medium<br>Slow<br>Off | Light<br>Normal<br><b>Heavy</b> | X                  | X         | X           | X          | X          |
|        | Cold Wash       | Hot<br>Very Warm<br>Warm<br>Cool<br><b>Cold</b> | Fast<br><b>Medium Fast</b><br>Medium<br>Slow<br>Off | Light<br>Normal<br><b>Heavy</b> |                    | X         | X           | X          | X          |
|        | Sanitize*       | <b>Hot</b>                                      | <b>Fast</b><br>Medium Fast<br>Medium<br>Slow<br>OFF | <b>Light</b><br>Normal<br>Heavy | X                  | X         | X           | X          | X          |
|        | Dry Only        |   |   |                                 |                    | X         |             |            |            |
| Colors | Normal          | Hot<br>Very Warm<br><b>Warm</b><br>Cool<br>Cold | Fast<br><b>Medium Fast</b><br>Medium<br>Slow<br>Off | <b>Light</b><br>Normal<br>Heavy | X                  | X         | X           | X          | X          |

\*This cycle eliminates 99.9% of the most common bacteria found in clothes, sheets, and towels. Using the highest wash temperature available ensures sanitization. Check recommended wash temperature of your items. Bacteria tested were K. pneumonia, P. aureginosa, and S. aureus.

| What   | How              | Basic Settings                                  |   |                                 | Additional Options |           |             |            |            |
|--------|------------------|---|---|---------------------------------|--------------------|-----------|-------------|------------|------------|
|        |                  | Temp  | Spin  | Soil                            | Steam Clean        | FanFresh® | Extra Rinse | Wash & Dry | Load & Go™ |
| Colors | Quick            | Hot<br>Very Warm<br><b>Warm</b><br>Cool<br>Cold | Fast<br><b>Medium Fast</b><br>Medium<br>Slow<br>Off | <b>Light</b><br>Normal<br>Heavy | X                  | X         | X           | X          | <b>X</b>   |
|        | Wrinkle Control  | Hot<br>Very Warm<br>Warm<br>Cool<br><b>Cold</b> | Fast<br>Medium Fast<br>Medium<br><b>Slow</b><br>Off | <b>Light</b><br>Normal<br>Heavy | X                  | X         | X           | X          | <b>X</b>   |
|        | Heavy Duty       | Hot<br><b>Very Warm</b><br>Warm<br>Cool<br>Cold | Fast<br><b>Medium Fast</b><br>Medium<br>Slow<br>Off | <b>Light</b><br>Normal<br>Heavy | X                  | X         | X           | X          | <b>X</b>   |
|        | <b>Cold Wash</b> | Hot<br>Very Warm<br>Warm<br>Cool<br><b>Cold</b> | Fast<br><b>Medium Fast</b><br>Medium<br>Slow<br>Off | <b>Light</b><br>Normal<br>Heavy |                    | X         | X           | X          | <b>X</b>   |
|        | Sanitize*        | <b>Hot</b>                                      | <b>Fast</b><br>Medium Fast<br>Medium<br>Slow<br>OFF | <b>Light</b><br>Normal<br>Heavy | X                  | X         | X           | X          | <b>X</b>   |
|        | Dry Only         |   |   |                                 |                    | X         |             |            |            |
| Towels | Normal           | Hot<br>Very Warm<br><b>Warm</b><br>Cool<br>Cold | <b>Fast</b><br>Medium Fast<br>Medium<br>Slow<br>Off | Light<br>Normal<br><b>Heavy</b> | X                  | X         | X           | X          | <b>X</b>   |
|        | Quick            | Hot<br>Very Warm<br><b>Warm</b><br>Cool<br>Cold | <b>Fast</b><br>Medium Fast<br>Medium<br>Slow<br>Off | <b>Light</b><br>Normal<br>Heavy | X                  | X         | X           | X          | <b>X</b>   |

\*This cycle eliminates 99.9% of the most common bacteria found in clothes, sheets, and towels. Using the highest wash temperature available ensures sanitization. Check recommended wash temperature of your items. Bacteria tested were K. pneumonia, P. aureginosa, and S. aureus.

| What   | How               | Basic Settings                                  |  |                                 | Additional Options |           |             |            |            |
|--------|-------------------|---|--|---------------------------------|--------------------|-----------|-------------|------------|------------|
|        |                   | Temp  | Spin   | Soil                            | Steam Clean        | FanFresh® | Extra Rinse | Wash & Dry | Load & Go™ |
| Towels | Wrinkle Control   | Hot<br>Very Warm<br>Warm<br>Cool<br><b>Cold</b> | Fast<br>Medium Fast<br>Medium<br><b>Slow</b><br>Off        | <b>Light</b><br>Normal<br>Heavy | X                  | X         | X           | X          | <b>X</b>   |
|        | <b>Heavy Duty</b> | Hot<br><b>Very Warm</b><br>Warm<br>Cool<br>Cold | <b>Fast</b><br>Medium Fast<br>Medium<br><b>Slow</b><br>Off | Light<br>Normal<br><b>Heavy</b> | X                  | X         | X           | X          | <b>X</b>   |
|        | Cold Wash         | Hot<br>Very Warm<br>Warm<br>Cool<br><b>Cold</b> | <b>Fast</b><br>Medium Fast<br>Medium<br>Slow<br>Off        | Light<br>Normal<br><b>Heavy</b> |                    | X         | X           | X          | <b>X</b>   |
|        | Sanitize*         | <b>Hot</b>                                      | <b>Fast</b><br>Medium Fast<br>Medium<br>Slow<br>OFF        | <b>Light</b><br>Normal<br>Heavy | X                  | X         | X           | X          | <b>X</b>   |
|        | Dry Only          |   |  |                                 |                    | X         |             |            |            |

\*This cycle eliminates 99.9% of the most common bacteria found in clothes, sheets, and towels. Using the highest wash temperature available ensures sanitization. Check recommended wash temperature of your items. Bacteria tested were K. pneumonia, P. aereginosa, and S. aureus.

# TROUBLESHOOTING

First try the solutions suggested here or visit our website at [www.whirlpool.com.tw](http://www.whirlpool.com.tw)

| If you experience  | Possible Causes   | Solution  |
|--|---|---|
| <b>Error Code Appears in Display (for 2- and 3-digit displays)</b>   |   |   |
| Once any possible issues are corrected, touch POWER once to clear the code. Reselect and restart the cycle.                                      |   |   |
| "Sd" or "Sud"<br>(excess suds) appears in display  | Excessive suds in washer dryer. Washer dryer is running a suds-reduction routine.                                 | Allow the washer dryer to continue. Use only HE detergent. Always follow the detergent manufacturer's instructions to determine the amount of detergent to use and base detergent quantity on load size. Not all detergents labeled as High Efficiency are identical in formulation and their ability to reduce suds. For example, natural, organic, or homemade HE detergents may generate a high level of suds. If you use one of these and see an "Sd" or "Sud" error code appear in the display, consider using a different HE detergent. |
| "Lo" followed by "FL" or "F8" followed by "E1" or<br>"Lo" followed by "FL" or "F08" followed by "E01"<br>(water supply error) appears in display | Check for proper water supply.  | Unit will drain for 8 minutes while door remains locked. The drain cycle must be allowed to complete or the error code cannot reset. When complete, touch POWER once to clear the code. Then touch POWER again to restart washer dryer. If code appears again, call for service.  |
|  |   | Both hoses must be attached and have water flowing to the inlet valve.  |
|  |   | Both hot and cold water faucets must be ON.   |
|  |   | Check that inlet valve screens are not clogged.   |
|  |   | Remove any kinks in the inlet hose.   |
|  | If used, auto shut-off connectors and hoses must be properly installed and in working order.                      |   |
|  | Check for proper inlet hoses.   | Use only manufacturer's recommended inlet hoses.  |
| "F9" followed by "E1" or<br>"F09" followed by "E01"<br>(drain pump system error) appears in display  | Check plumbing for correct drain hose installation. Drain hose extends into standpipe farther than 4½" (11.4 cm). | Check drain hose for proper installation.   |
|  |   | Make sure the drain hose is not kinked, pinched, or blocked.  |
|  |   | Remove any clogs from drain hose.   |
|  |   | Use drain hose form and securely attach to drainpipe or tub.  |
|  | Lower drain hose if the end is higher than 96" (2.4 m) above the floor.   |   |
|  | Not using HE detergent or using too much HE detergent.  | Use only HE detergent. Always measure detergent and follow manufacturer's directions based on load size and soil level.   |
| "F5" followed by "E2" or<br>"F05" followed by "E02"<br>(door will not lock) appears in display   | Washer dryer door not locking.  | Touch POWER to cancel the cycle. Check that the door is closed completely and latching. Check for items in the washer dryer drum that may be keeping the door from closing completely.  |
| "rL" (remove load) appears in display  | Load detected in drum during Clean Washer with affresh cycle.   | Remove items from washer dryer drum and restart Clean Washer with affresh cycle.  |
| "PF"   | Appears upon recovery from power loss, if power was lost while running a cycle.                                   | Touch POWER once to clear the code. Then touch POWER again and restart the washer dryer.  |

# TROUBLESHOOTING

## ⚠ WARNING



### Electrical Shock Hazard

**Plug into a grounded 3 prong outlet.**

**Do not remove ground prong.**

**Do not use an adapter.**

**Do not use an extension cord.**

**Failure to follow these instructions can result in death, fire, or electrical shock.**

First try the solutions suggested here or visit our website at [www.whirlpool.com.tw](http://www.whirlpool.com.tw)

| If you experience  | Possible Causes   | Solution  |
|--|---|---|
| <b>Error Code Appears in Display (for 2- and 3-digit displays) (cont.)</b> |   |   |
| F# E# or F## E## code other than as described above appears in display     | System error code.  | Touch POWER once to clear the code. Then touch POWER again to restart washer dryer. If code appears again, call for service. Unplug washer dryer for 30 seconds, then plug back in.   |
| Washer dryer making error beeps  | Door has not been opened and closed for at least 3 cycles.  | This code may occur when the washer dryer is first turned on. Open and close the door to clear the display.   |
| Washer dryer beeps when START is touched                                   | Door not closed.  | Close the door completely.  |
| Clean Washer LED flashing at end of wash cycle (on some models)            | The washer dryer has run 30 wash cycles and is indicating a reminder to run the Clean Washer with affresh cycle.              | Run the Clean Washer with affresh cycle. If the Clean Washer with affresh cycle is not turned on, the LED will stop flashing at the end of a wash cycle after running 3 more regular wash cycles. After 30 more wash cycles are completed, the Clean Washer with affresh LED will again flash at the end of a wash cycle as a reminder. |
| "Cool Down" appears in display   | During normal operation, this icon may appear during the end of the dry cycle if the load needs additional time to cool down. | It is normal for the icon to appear, it will disappear when cool down has finished.   |

# TROUBLESHOOTING

First try the solutions suggested here or visit our website at [www.whirlpool.com.tw](http://www.whirlpool.com.tw)

| If you experience  | Possible Causes  | Solution   |
|--|--|--|
| <b>Vibration or Off-Balance</b>                                  |  |  |
| Vibration, rocking, or "walking"                                 | Feet may not be in contact with the floor and locked.                            | Front and rear feet must be in firm contact with floor and washer dryer must be level to operate properly. Jam nuts must be tight against the bottom of the cabinet.   |
|  | Washer dryer may not be level.   | Check floor for flexing or sagging. If flooring is uneven, a 3/4" (1.9 cm) piece of plywood under your washer dryer will reduce sound. Do not install washer dryer on a raised wooden platform.  |
|  |  | See "Level All-In-One Washer Dryer" in Installation Instructions.  |
|  | Load could be unbalanced or too large.   | Avoid tightly packing the load. Avoid washing single items. Balance a single item such as a rug or jeans jacket with a few extra items.<br>Item or load is not suitable for selected cycle. See "All-In-One Washer Dryer Cycle Guide" and "Using Your Washer Dryer." |
| The shipping bolts are still in the back of the washer dryer.    | See "Remove transport bolts from Washer Dryer" in the Installation Instructions. |  |
| <b>Noises</b>  |  |  |
| Clicking or metallic noises                                      | Door locking or unlocking.   | After starting a cycle the drum will make a partial turn and the door will lock. The door will remain locked until the end of cycle. This is normal.   |
|  | Objects caught in washer dryer drain system.                                     | Empty pockets before washing. Loose items such as coins could fall between washer dryer drum and tub or may block pump. It may be necessary to call for service to remove items.   |
|  |  | It is normal to hear metal items on clothing, such as metal snaps, buckles, or zippers, touch against the stainless steel drum.  |
| Gurgling or humming  | Washer dryer may be draining water.  | The pump may make a humming sound with periodic gurgling or surging as final amounts of water are removed during the spin/drain cycles. This is normal at certain stages of the cycle.   |
| Rolling or sloshing and occasional clicking (on slow-speed spin) | Steel balls in the balancing system are balancing the load.                      | This is normal at certain stages of the cycle.   |
| <b>Water Leaks</b>   |  |  |
| Check the following for proper installation                      | Fill hoses not attached tightly.   | Tighten fill-hose connection.  |
|  | Fill-hose washers.   | Properly seat all four fill-hose flat washers.   |
|  | Drain hose connection.   | Check that the drain hose is properly secured to drainpipe or laundry tub.   |
|  | On some models: Drain pump filter is not properly seated.                        | On some models: Make sure filter is correctly placed in the housing. See "Cleaning the Drain Pump Filter/Draining Residual Water."   |
|  | Check household plumbing for leaks or clogged sink or drain.                     | Water can back up out of a clogged sink or drainpipe. Check all household plumbing for leaks (laundry tubs, drain pipe, water pipes, and faucets).   |
|  | Strainer (or nylon stocking) on end of drain hose is clogged.                    | Remove strainer/nylon stocking from drain hose.  |

# TROUBLESHOOTING

## ⚠ WARNING



### Electrical Shock Hazard

**Plug into a grounded 3 prong outlet.**

**Do not remove ground prong.**

**Do not use an adapter.**

**Do not use an extension cord.**

**Failure to follow these instructions can result in death, fire, or electrical shock.**

First try the solutions suggested here or visit our website at [www.whirlpool.com.tw](http://www.whirlpool.com.tw)

| If you experience  | Possible Causes   | Solution   |
|--|---|--|
| <b>Water Leaks (cont.)</b>                                 |   |  |
| Water or suds leaking from door or rear of cabinet         | Not using HE detergent or using too much HE detergent.  | Only use HE detergent. Suds from regular detergents can cause leaking from the door or rear of cabinet. Always measure detergent and follow manufacturer's directions based on your load requirements. |
|  | Using thickened, easy-pour, or no-splash bleach when running the Clean Washer with affresh cycle. | Use affresh tablet or regular, non-thickened chlorine bleach when running the Clean Washer with affresh cycle.   |
|  | Residue on door window.   | Periodically clean the underside of the glass window to avoid potential leaks.   |
|  | Door opened during "Add Garment."   | Water can drip off the inside of the door when the door is opened after the start of a cycle.  |
| Leaking around door  | Hair, lint, or other debris on inner door glass preventing proper seal with rubber door seal.     | Clean inner door window and seal. See "Cleaning the Door Seal" in the "Washer Dryer Maintenance" section.  |
| <b>Washer dryer not performing as expected</b>             |   |  |
| Load not completely covered in water                       | Water level not visible on door or does not cover clothes.  | This is normal for an HE front-load washer dryer. The washer dryer senses load sizes and adds the correct amount of water for optimal cleaning.  |
| Washer dryer won't run or fill; washer dryer stops working | Check for proper water supply.  | Both hoses must be attached and have water flowing to the inlet valve.   |
|  |   | Both hot and cold water faucets must be turned on.   |
|  |   | Check that inlet valve screens have not become clogged.  |
|  |   | Check for any kinks in inlet hoses, which can restrict water flow.   |
|  | Check proper electrical supply.   | Plug power cord into a grounded 3 prong outlet.  |
|  |   | Do not use an extension cord.  |
|  |   | Ensure there is power to outlet.   |
|  |   | Do not plug into a GFCI (Ground Fault Circuit Interrupter).  |
|  | Check electrical source or call an electrician to check if voltage is low.                        |  |
|  | Reset a tripped circuit breaker. Replace any blown fuses.   |  |
|  | <b>NOTE:</b> If problems continue, contact an electrician.  |  |



# TROUBLESHOOTING

First try the solutions suggested here or visit our website at [www.whirlpool.com.tw](http://www.whirlpool.com.tw)

| If you experience  | Possible Causes   | Solution   |
|--|---|--|
| <b>Washer dryer not performing as expected (cont.)</b>             |   |  |
| Washer dryer won't run or fill; washer dryer stops working (cont.) | The load size is being sensed.  | After the load size is sensed, the estimated time based on load size will be displayed and water will be added.  |
|  | Normal washer dryer operation.  | Door must be completely closed and latched for washer dryer to run.  |
|  |   | The washer dryer pauses for about 2 minutes during certain cycles. Allow the cycle to continue. Some cycles feature periods of tumbling and soak.  |
|  |   | Washer dryer may be stopped to reduce suds. Use only a proper amount of HE detergent.  |
|  |   | Cold Wash uses less water in the beginning of the cycle to provide a high concentration of detergent for optimal cleaning action. Following this concentrated tumbling, more water is used to complete the wash.   |
|  |   | During the first 20 minutes of the Clean Washer with affresh cycle, it will activate the steamer but the drum will not spin or fill with water. You may see condensation on the door glass during this initial phase. If you are using an affresh Washer Cleaner tablet, it will not dissolve completely during the steam phase. This is normal. |
|  | The washer dryer door is not firmly shut.   | The door must be closed during operation.  |
|  | On some models: The Load & Go bulk dispenser is not fully seated in the washer dryer.   | Make sure that the Load & Go bulk dispenser is fully seated in the washer dryer, and that the lid on the bulk dispenser is firmly closed.  |
|  | Washer dryer not loaded as recommended.   | Remove several items and rearrange load evenly in washer dryer drum. Close door, then touch and hold START/PAUSE.  |
|  |   | Do not add more than 1 or 2 additional items after cycle has started to avoid tightly packing or unbalancing.  |
| Do not add more water to the washer dryer.                         |   |  |
| Not using HE detergent or using too much HE detergent.             | Only use HE detergent. Suds from regular detergents can slow or stop the washer dryer. Always measure detergent, following manufacturer's directions based on your load requirements. |  |
|  | To remove suds, cancel cycle. Select DRAIN & SPIN with EXTRA RINSE. Touch START/PAUSE. Do not add more detergent.   |  |
|  | Make sure the Load & Go bulk dispenser is disabled if you are using a single dose of detergent.   |  |
| Door not opened between cycles.                                    | After any wash cycle is completed, the door must be opened and then closed before a new cycle can begin.  |  |
| Washer dryer not draining/spinning; loads are still wet            | Drain hose extends into standpipe farther than 4.5" (11.4 cm).  | Check drain hose for proper installation. Use drain hose form and securely attach to drainpipe or tub. Do not tape over drain opening.   |
|  | The drain hose is clogged or the end of the drain hose is more than 96" (2.4 m) above the floor.  | Lower drain hose if the end is higher than 96" (2.4 m) above the floor. Remove any clogs from drain hose. See "Installation Requirements" in Installation Instructions.  |
|  | Strainer/nylon stocking on end of drain hose.   | Remove strainer/nylon stocking from drain hose.  |
|  | The drain hose fits too tightly in the standpipe or it is taped to the standpipe.   | The drain hose should be loose, yet fit securely. Do not seal the drain hose with tape. The hose needs an air gap. See "Secure the Drain Hose" in Installation Instructions.   |

# TROUBLESHOOTING

First try the solutions suggested here or visit our website at [www.whirlpool.com.tw](http://www.whirlpool.com.tw)

| If you experience   | Possible Causes  | Solution   |
|---|--|--|
| <b>Washer dryer not performing as expected (cont.)</b>          |  |  |
| Washer dryer not draining/spinning; loads are still wet (cont.) | Using cycles with a slower spin speed.   | Cycles with slower spin speeds remove less water than cycles with fast spin speeds. Use the recommended cycle/speed spin for your garment.   |
|   | Washer dryer not loaded as recommended.  | A tightly packed or unbalanced load may not allow the washer dryer to spin correctly, leaving the load wetter than normal. See "Cycle Guide" for load size recommendation for each cycle.  |
|   | The load may be out of balance.  | Avoid washing single items. Balance a single item, such as a rug or jeans jacket, with a few extra items.  |
|   | Not using HE detergent or using too much HE detergent.   | Use only HE detergent. Suds from regular detergent or using too much detergent can slow or stop draining or spinning. Always measure and follow manufacturer's directions for your load. To remove extra suds, select DRAIN & SPIN with EXTRA RINSE. Do not add detergent. |
|   | Small items may have been caught in the pump or stuck between the washer dryer drum and the outer tub.         | Check the drum for any items sticking through the drum holes. Empty pockets and use garment bags when washing small items.   |
|   | On some models: Drain pump filter is dirty.  | On some models: Clean drain pump filter. See "Cleaning the Drain Pump Filter/Draining Residual Water."   |
|   | Wash cycle has been canceled and door opened before water has drained.   | Run Drain & Spin to remove any excess water.   |
| Washer dryer is spinning clothes without water                  | The washer dryer is measuring the mass of the dry load.  | This measurement is normal and ensures the best cycle time for your load.  |
| Door locked at end of wash cycle                                | Water remaining in washer dryer after cycle.   | Select DRAIN & SPIN to remove any water remaining in the washer dryer. The washer dryer door will unlock at the end of the drain.  |
| Door will not unlock  | Door locks when cycle has started.   | If the "Add Garment" light is lit, touch START/PAUSE once. The door will unlock.   |
| Incorrect or wrong wash or rinse temperatures                   | Check for proper water supply.   | Make sure hot and cold inlet hoses are not reversed.   |
|   |  | Both hoses must be attached to both washer dryer and faucet, and have both hot and cold water flowing to inlet valve.  |
|   |  | Check that inlet valve screens are not clogged.  |
|   | Remove any kinks in hoses.   |  |
|   | Washing many loads.  | Your hot water tank may not have enough hot water to keep up with the number of hot or warm washes. This is normal.  |
| Desired setting or option does not light                        | For best performance, not all settings are available with each cycle and some options cannot be used together. | See the "Cycle Guide" for the available settings and options for each cycle.   |
| Load not rinsed   | Check for proper water supply.   | Make sure hot and cold inlet hoses are not reversed.   |
|   |  | Both hoses must be attached and have water flowing to the inlet valve.   |
|   |  | Both hot and cold water faucets must be on.  |
|   |  | Check that inlet valve screens are not clogged.  |
|   |  | Remove any kinks in the inlet hose.  |
|   | Not using HE detergent or using too much HE detergent.   | The suds from non-HE detergent can cause the washer dryer to operate incorrectly.<br>Use only HE detergent. Always measure detergent and follow manufacturer's directions based on load size and soil level.   |

# TROUBLESHOOTING

First try the solutions suggested here or visit our website at [www.whirlpool.com.tw](http://www.whirlpool.com.tw)

| If you experience                                      | Possible Causes   | Solution   |
|--|---|--|
| <b>Washer dryer not performing as expected (cont.)</b> |   |  |
| Load not rinsed (cont.)                                | Washer dryer not loaded as recommended.                 | <p>Avoid tightly packing the washer dryer. The washer dryer will not rinse well if tightly packed. Load with dry items only. See the “Cycle Guide” for load size recommendations for each cycle.</p> <p>Use cycle designed for the fabrics being washed.</p> <p>Add only one or two garments after washer dryer has started.</p> |
|  | The load may be out of balance.                         | When load imbalance occurs, a washing process will start to redistribute the load. This may lengthen the cycle time. Avoid washing single items. Balance a single item, such as a rug or jeans jacket, with a few extra items.   |
| Load is wrinkled, twisted, or tangled                  | Washer dryer not loaded as recommended.                 | <p>Add load loosely. Items need to move freely to reduce wrinkling and tangling. See the “Cycle Guide” for load size recommendations for each cycle.</p> <p>Reduce tangling by mixing types of load items. Use the recommended cycle for the type of garments being washed.</p>  |
|  | Wash action too long for load.                          | Select a lower soil level. Note that items will not be cleaned as deeply as when using a higher soil level.  |
|  | Spin speed too fast for load.                           | Select a slower spin speed. Note that items will be wetter than when using a faster speed spin.  |
|  | The washer dryer is not unloaded promptly.              | Unload the washer dryer as soon as it stops or use FanFresh® option if you will not be able to unload the washer dryer at the end of the cycle.  |
|  | Not choosing the right cycle for the load being washed. | Use the Delicates cycle or another cycle with a slow spin speed to reduce wrinkling.   |
|  | The wash water was not warm enough to relax wrinkles.   | If acceptable for load, use warm or hot wash water.  |
| Not cleaning or removing stains                        | Washer dryer not loaded as recommended.                 | <p>Add load loosely. Items need to move freely for best cleaning. See the “Cycle Guide” for load size recommendations for each cycle.</p> <p>Add only 1 or 2 garments after washer dryer has started.</p>  |
|  | Not using HE detergent or using too much HE detergent.  | Use only HE detergent. Always measure detergent and follow manufacturer’s directions based on load size and soil level.  |
|  | Hard water or high level of iron (rust) in water.       | You may need to install a water softener and/or iron filter.   |
|  | Fabric softener dispensing ball used.                   | Dispensing balls will not operate correctly with this washer dryer. Add liquid fabric softener to the fabric softener compartment.   |
|  | Powdered detergent used for slow-speed cycle.           | Consider using liquid detergent.   |

# TROUBLESHOOTING

First try the solutions suggested here or visit our website at [www.whirlpool.com.tw](http://www.whirlpool.com.tw)

| If you experience                                       | Possible Causes  | Solution   |
|---|--|--|
| <b>Washer dryer not performing as expected (cont.)</b>  |  |  |
| Not cleaning or removing stains (cont.)                 | Not using correct cycle for fabric type.   | Use a higher soil level setting and warmer wash temperature to improve cleaning.   |
|   |  | If using Quick Wash cycle, wash only a few items.  |
|   |  | Use Whites and Heavy Duty cycles for tough cleaning.   |
|   |  | Add an extra rinse for heavily soiled loads.   |
|   | Not using dispensers.  | Use dispensers to avoid chlorine bleach and fabric softener staining.  |
|   |  | Load dispensers before starting a cycle.   |
|   |  | On some models: Make sure that the Load & Go bulk dispense liquid detergent dispenser is not empty.  |
|   |  | Avoid overfilling.   |
|   |  | Do not add products other than those specified directly to load.   |
|   | Dispense cartridge is empty.   | Fill dispense cartridge to the "MAX" line with HE liquid detergent.  |
| Detergent dispenser is not securely in place.           | Pull out the dispenser, fill with detergent, and slide it back in place.   |  |
| Not washing like colors together.                       | Wash like colors together and remove promptly after the cycle is complete to avoid dye transfer.                           |  |
| Hard water or not enough detergent used.                | Use more detergent for washing heavy soils in cold or hard water.  |  |
|   | Touch WATER HARDNESS (on some models) to change water hardness to "hard."  |  |
| Odors   | Monthly maintenance not done as recommended.   | Run the Clean Washer with affresh cycle monthly or every 30 wash cycles. See "Washer Dryer Care" in "Washer Dryer Maintenance."                          |
|   |  | Unload washer dryer as soon as cycle is complete. Use the Fresh Hold/Fresh Spin option if load cannot be removed immediately after the wash is complete. |
|   | Not using HE detergent or using too much HE detergent.   | Use only HE detergent. Be sure to measure correctly. Always follow the manufacturer's directions.<br>See "Washer Dryer Care" section.                    |
|   | Door not left open after use.  | This washer dryer has a tight seal to avoid water leaks. To avoid odors, leave the door open to allow the washer to dry between uses.                    |
| Fabric damage   | Sharp items were in pockets during wash cycle.   | Empty pockets, zip zippers, and snap or hook fasteners before washing to avoid snags and tears.  |
|   | Strings and straps could have tangled.   | Tie all strings and straps before starting wash load.  |
|   | Items may have been damaged before washing.  | Mend rips and broken threads in seams before washing.  |
|   | Fabric damage can occur if washer dryer is tightly packed.   | Avoid tightly packing the washer dryer. Load with dry items only.  |
|   |  | Use cycle designed for the fabrics being washed.   |
|   |  | Add only one or two garments after washer dryer has started.   |
|   | Fabric damage can occur if washer dryer door is closed on an item, trapping it between the door glass and the rubber seal. | Do not overfill the washer dryer.  |
|   |  | Push wash load fully into the washer dryer.  |
| Liquid chlorine bleach may have been added incorrectly. | Do not pour liquid chlorine bleach directly onto load. Wipe up bleach spills.  |  |
|   | Undiluted bleach will damage fabrics. Do not use more than recommended by manufacturer.                                    |  |

# TROUBLESHOOTING

First try the solutions suggested here or visit our website at [www.whirlpool.com.tw](http://www.whirlpool.com.tw)

| If you experience  | Possible Causes   | Solution  |
|--|---|---|
| <b>Washer dryer not performing as expected (cont.)</b>   |   |   |
| Gray whites, dingy colors  | Load not sorted properly.                                   | The transfer of dye can occur when mixing whites and colors in a load. Sort dark clothes from whites and lights.  |
|  | Wash temperatures too low.                                  | Use hot or warm temperatures if acceptable for the load. Make sure your hot water system is adequate to provide a hot water wash.   |
|  | Hard water or not enough detergent used.                    | Use more detergent for washing heavy soils in cold or hard water.   |
| Incorrect dispenser operation  | Clogged dispensers or laundry products dispensing too soon. | Do not overfill dispenser. Overfilling causes immediate dispensing.   |
|  |   | Load dispensers before starting a cycle.  |
|  |   | Homes with low water pressure may result in residual powder in the dispenser. To avoid, select a warmer wash temperature if possible, depending on your load.   |
|  | Liquid chlorine bleach not used in bleach compartment.      | Use only liquid chlorine bleach in the bleach compartment.  |
|  | Water in dispenser after cycle has finished.                | It is normal for small amounts of water to remain in dispenser at the end of the cycle.   |
| Single-dose laundry packet not dissolving  | Adding laundry packet incorrectly.                          | Be sure laundry packet is added to washer dryer drum before adding clothes. Do not add packet to dispenser. Follow the manufacturer's instructions to avoid damage to your garments.                                    |
| Cycle time changes or cycle time too long  | Normal washer dryer operation.                              | The cycle times vary automatically based on your water pressure, water temperature, detergent, and clothes load. The options you select will also affect the cycle times.   |
|  | Excessive suds in washer dryer                              | When excessive suds are detected, a special suds routine automatically starts to remove extra suds and ensure proper rinsing of your garments. This routine will add time to the original cycle.                        |
|  | Load may be out of balance.                                 | When load unbalance occurs, a washing process will start to redistribute the load. This extends the cycle time. Avoid washing single items. Balance a single item such as a rug or jeans jacket with a few extra items. |
|  | Not using correct cycle for load type.                      | The Quick Wash cycle is designed for smaller load sizes (2–4 items) of lightly soiled garments. If larger loads are washed in this cycle, cycle time will be increased.   |
| When using the Quick Wash or Delicates cycle, you should wash small loads. This ensures a gentle wash for your garments without increasing cycle time. |   |   |
| The controls are not responding  | Control Lock is ON.   | Touch and hold CONTROL LOCK for 3 seconds to turn off Control Lock. For each second CONTROL LOCK is held down, the display will count down one second, you will see "3," then "2," then "1."                            |
| <b>Drying Results</b>  |   |   |
| Clothes are not drying satisfactorily or drying times are too long   | The load is too large and heavy to dry quickly.             | Separate the load to tumble freely. Loading drum a quarter full or less will improve drying performance and cycle time. Run a high-speed spin cycle.  |
| Lint on load   | Area under door seal is clogged with lint.                  | Gently pull back the rubber door seal and clean lint with the textured side of an affresh Machine Cleaning Wipe.  |
|  | On some models: Drain pump filter is clogged with lint.     | On some models: Clean the drain pump filter. See "Cleaning the Drain Pump Filter/Draining Residual Water." This procedure should be performed occasionally.   |

# TROUBLESHOOTING

First try the solutions suggested here or visit our website at [www.whirlpool.com.tw](http://www.whirlpool.com.tw)

| If you experience             | Possible Causes  | Solution  |
|-------------------------------|--|---|
| <b>Drying Results (cont.)</b> |  |   |
| Dried loads are wrinkled      | The load was not removed from the washer dryer at the end of the drying cycle. | Remove garments promptly at the end of the drying cycle, or use the FanFresh® option.   |
|                               | The washer dryer was tightly packed.   | Dry smaller loads that can tumble freely. Loading drum a quarter full or less will improve drying performance and cycle time. Results may also vary depending on fabric type.   |
| Load too hot                  | Load removed before cool-down portion of cycle is complete.                    | Allow the drying cycle to complete the cool-down portion of the cycle before removing the load. If you cancel the cycle before the cool-down portion of the cycle and immediately remove the load, it will be very hot. |

# NOTES

