

# PHILIPS

RO Dispenser

ADD6901



User Manual  
說明書

## CONTENTS

---

1 Important notes 01

---

2 Product specifications 03

---

3 Product overview 03

---

4 User interface 04

---

5 Installation 04

---

6 Usage instructions 05

---

---

7 Daily maintenance 8

---

8 Filter replacement 9

---

9 Error codes 10

---

10 Troubleshooting 11

---

11 Packing list 12

---

12 Guarantee and support 12

---

# 1. Important notes

Note: All contents of this part relate to safety. The dangers, harmfulness, and potential accidents are explained herein. All users must strictly follow the instructions.

- Misuse may cause injury.
- The heating element surface is subject to residual heat after use.
- This appliance is intended for household and indoor use only.
- Do not immerse the appliance in any liquid.
- Do not use accessories which are not authorised by the manufacturer. The warranty will terminate automatically if machine failure is caused by unauthorised accessories.
- Please check for machine damages and verify all parts are included after unpacking.
- Keep the plastic bag or film away from babies and children to avoid suffocation.
- Use municipal tap water as the water source.
- Please do not pour unknown liquids, water from sources of unknown quality or other extraneous materials of any sort into the tap water tank and filtered water tank.
- Please handle the machine with care to avoid injuries or damages resulting from dropping the appliance.
- Place the machine out of reach of children and pets.
- Children and persons incapable of operating the machine safely should use the machine under the supervision of a guardian.
- Place the machine in a cool and dry place, away from direct sunlight. Do not place it near any form of heat source.
- The machine shall not be placed in an environment that may have inflammable gas leakage.
- To avoid electric shock, do not touch the power plug with wet hands.
- To avoid damage, do not disassemble or modify the machine, or put any heavy objects on it.
- If the dispenser will not be used for a long time, please make sure it is disconnected from the power supply, and empty the tap water tank and filtered water tank.
- The inlet water temperature should be 5°C-38°C. If the temperature is higher than 38°C, the filter cartridge will be damaged and be unable to work. If the temperature is lower than 5°C, the dispenser might be frozen and the elements of the dispenser will be damaged.
- The dispenser can only be installed and used indoors, and with a power supply of reliable grounding.
- For first time use, or if the machine hasn't been used for a long time, fill the tap water tank and discard all the filtered water. Repeat this twice.
- Always use certified elements and accessories for the repairment and maintenance of the dispenser.

- Organic solvents such as gasoline shall not be used for wiping the housing of the dispenser. If cleaning is required, please gently wipe the surface of the product with a wet cloth after it is disconnected from power supply.
- If there is any abnormality, unplug the product from the power supply immediately, and do not leave the defective dispenser in working mode.
- With an upgrade of the product certain words or pictures on the manual may be different from the actual product, and the actual product shall govern in this case.
- If the user intends to extract ambient water or water of 45°C immediately after extracting hot water, some hot water may come out at the beginning, if so please watch out to avoid being burnt by the hot water. It is recommended to extract ambient water for 10 seconds to cool down the heating element.
- If the power cord appears to be damaged, please stop using the product. To avoid risks of danger, the power cord must be replaced by personnel authorised by the manufacturer.
- Do not disassemble or repair it the dispenser by yourself, nor hand it over to any person not authorized to repair, as improper repairing may cause risks of danger.
- The manufacturer will not bear responsibility for any consequences that are the results of failure to operate the appliance in accordance with the above guidelines.

## 2. Product specifications

Product name	Philips RO water dispenser
Model	ADD6901H
Rated voltage	220V-240V~
Total rated power	2000W-2400W
Water heating capacity	20L/h, $\geq 90^{\circ}\text{C}$ (Max.95 $^{\circ}\text{C}$ )
Filtration capacity	2000L
Water filtration flow rate	0.13L/min
Applicable water source	Municipal tap water
Inlet water pressure	0 - 0.06MPa
Applicable water temperature	5-38 $^{\circ}\text{C}$

## 3. Product overview

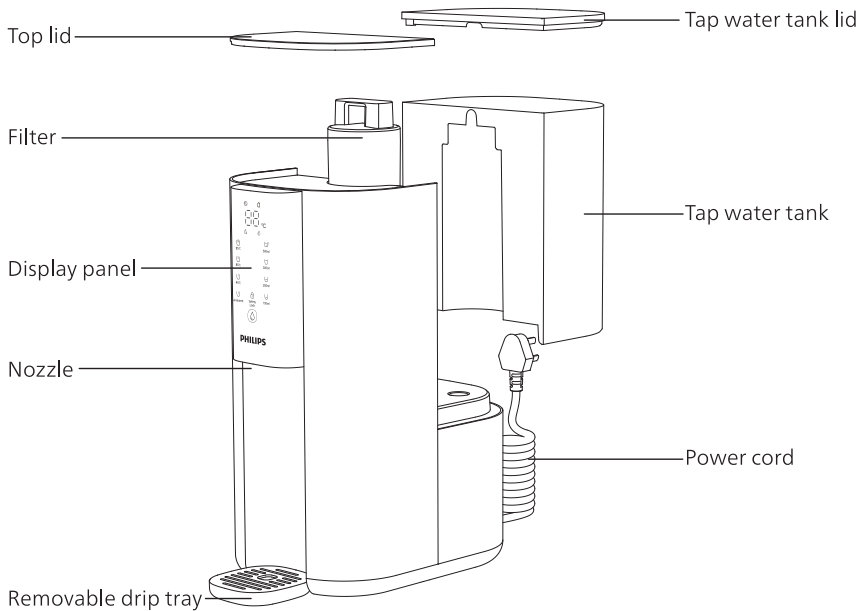

**Note:** Illustration image is for reference only.

# 4. User interface

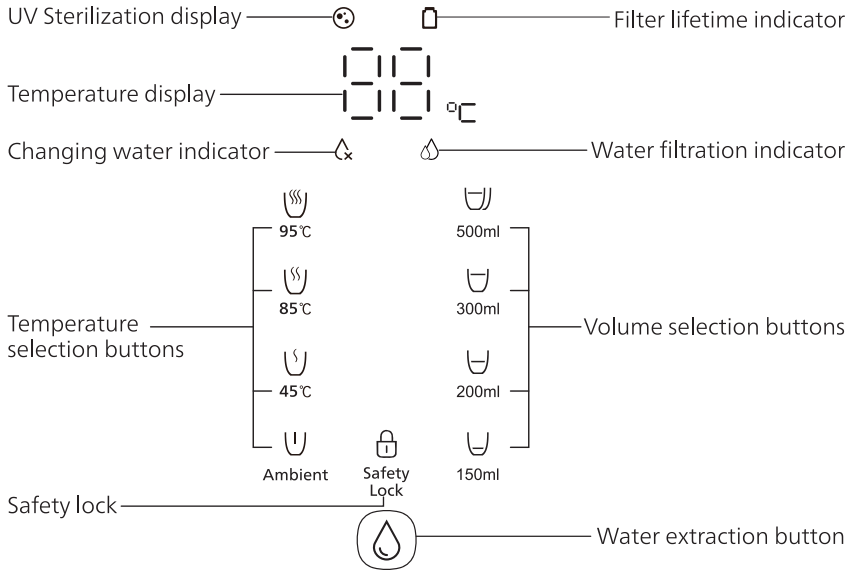

There could be a temperature deviation of  $\pm 3^{\circ}\text{C}$  and a volume deviation of  $\pm 10\%$ , the actual temperature and volume depends on usage environment and local tap water quality.

# 5. Installation

## Setup

- Place the machine on a cool and stable surface with good ventilation, and far away from any heat source.
- Remove the tap water tank lid and lift the tank upwards; fill the tap water tank with tap water and place it back the machine, then place the lid back to the tap water tank properly.
- Plug the power cord into a power socket, the machine will make sounds then the display panel will light up, indicating that the machine is working.

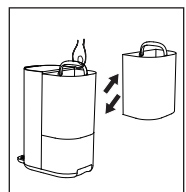
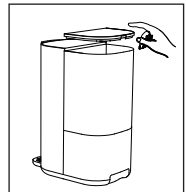

## First time use

- During first time use, please check if any water leaks from or gathers around the dispenser, if there is any strange noise, burnt smell or smoke coming out from the product, please disconnect the power cord and contact customer services.
- For first time use, in order to ensure the best filtration performance, fill the tap water tank and discard all the filtered water. You may press and hold “  $\frac{\text{U}}{85^\circ\text{C}}$  +  $\frac{\text{U}}{300\text{ml}}$  ” for 3 seconds to empty the tank and pipes when filtration is completed. Repeat this until two tanks of tap water are filtered.
- For first time use, in order to avoid dry-heating and protect the machine, please extract some ambient water before extracting hot water.

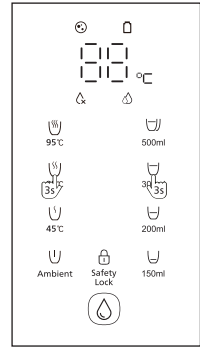

## 6. Usage instructions

### Safety lock

- Safety lock and temperature memory mode: The machine will memorize the last selected water temperature, unlocking is required and press “  $\frac{\text{U}}{\text{Safety Lock}}$  ” before extraction of hot water. The machine will be locked automatically if no keys are pressed within 10 seconds. Press the safety lock key for 10 seconds to disable the safety lock and temperature memory. The machine returns to “Ambient” after water extraction if the safety lock is disabled. Press the safety lock key for 10 seconds to enable the safety lock and temperature memory again.

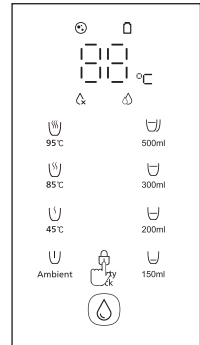

### Rinsing

- The dispenser will do auto rinsing before and after water filtration once it is connected with the power supply and the water tank is covered.
- Forced rinsing: long press “  $\frac{\text{U}}{\text{Ambient}}$  +  $\frac{\text{U}}{\text{Safety Lock}}$  ” for 3 seconds and the dispenser will rinse for 3 minutes.

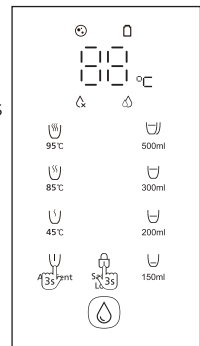

## Water filtration

- If the built-in filtered water tank is at a low water level, the dispenser will automatically start to filter the tap water until the filtration is done. In the state of water filtration, the water filtration indicator is always on, and when the filtered water tank is short of water, changing water and water filtration indicator flash.

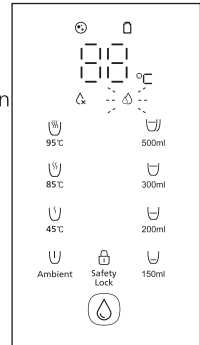

## Water temperature adjustment

- Water temperature presets: there are four water temperature presets for selection: " Ambient " " 45°C " " 85°C " and " 95°C " .

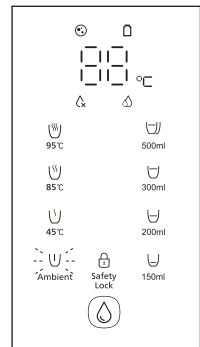

## Water volume adjustment

- Water volume presets: There are four water volume presets for selection:

" 150ml " " 200ml " " 300ml " and " 500ml " .

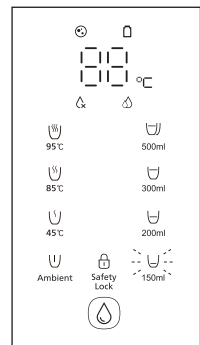





## Water extraction

- Select the water temperature and volume, and the display screen will display the selected water temperature. After pressing the safety lock (ambient water is automatically unlocked), press the water extraction button to extract purified water with the corresponding temperature and volume. You can press any button to stop during the extraction process.

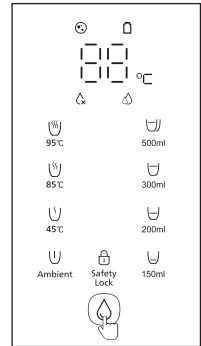
**Note:** When extracting hot water, do not place your hand under the nozzle to avoid scalding.



## Changing water

When the indicator of “” flashes, the water in the tap water tank needs to be changed, which will happen in the following conditions:

- Water in the tap water tank is at or less than the lowest water level;
- The TDS value of the tap water is too high;
- The water in the tap water tank is not changed within 48 hours. To change the water in the tap water tank, open the lid of the tap water tank, lift the tap water tank upward and discard the drain water, fill the tap water tank with tap water, place it back to the machine and close the lid properly.

**Note:** Do not add water into the tap water tank without discarding the drain water.

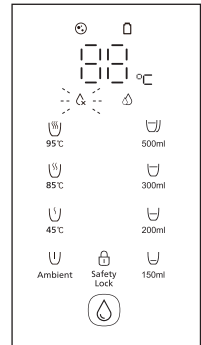

## Winter mode

- When the tap water temperature is lower than 10°C, winter mode can be set.
- Long press the ambient button for 3 seconds, and then press the water extraction button to extract 25°C filtered water. This is valid for a single operation only.

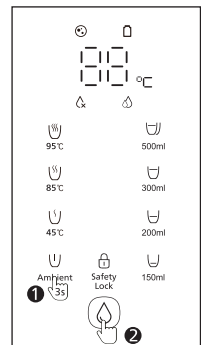

## Sleep mode

- If there is no operation within 1 minute, the dispenser will automatically go to sleep mode.
- When the dispenser is in sleep mode, only the safety lock indicator is on, and all other indicators are off.
- Touch any button to end the sleep mode.

## Emptying the tank and pipes

- Long press "85°C" button and "300ml" button for 3 seconds, the dispenser will extract water until the filtered water tank and the inner pipes are empty.

**Note:** In order to avoid dry-heating, if the tank and pipes have been emptied, please extract some ambient water before extracting hot water.

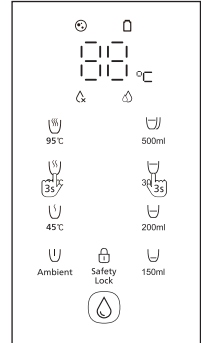

# 7. Daily maintenance

If the product is not used for over two days, it is suggested to change the water in the tap water tank and then empty the tank and pipes twice.

If the dispenser will not be used for over one week, please use one-key emptying to empty the water tank and disconnect the dispenser from the power supply. Seal the filter cartridge and store it in the refrigerator (2-5°C, do not put it into the freezer). When you use it again, please follow the cleaning procedures for first time use.

### Tap water tank descaling

- It is recommended to descale the tap water tank every 3 months to avoid scale build-up in the tap water tank.
- Descaling procedure: fill the tap water tank to half-way and add 30g of citric acid. Stir lightly then soak for 2 hours (do not place the tap water tank back to the dispenser). Then discard the citric acid solution and clean the entire water tank with tap water.

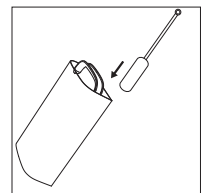

\* Please purchase the cleaning brush and citric acid separately.

# 8. Filter replacement

Please change the filter cartridges according to the filter lifetime indicator on the display panel, or the suggested replacement cycle. New filter cartridge can be purchased from authorized retailers and service centers. The model is ADD541.

Name	RO Filter
Model	ADD541
Suggested Replacement Cycle	1 year
* Only the original Philips filter cartridge can be used.	

## Filter lifetime indicator

- The color of the filter lifetime indicator shows the remaining lifetime of the filter cartridge:
  - Blue light: more than 10% lifetime left;
  - Flashing red light: less than 10% lifetime left;
  - Constant red light: less than 7-day lifetime left and please replace the filter now.

## Filter cartridge replacement instructions

- Power off.
- Take out the tap water tank and then the machine's top lid.
- Rotate the used filter cartridge counterclockwise to the unlock "U" position and take it out.
- Insert the new filter cartridge into the dispenser. Rotate it clockwise to the lock "L" position and cover the machine's top lid; put the tap water tank back to the dispenser.
- Reset the filter cartridge lifetime and follow the cleaning procedures for first time use.

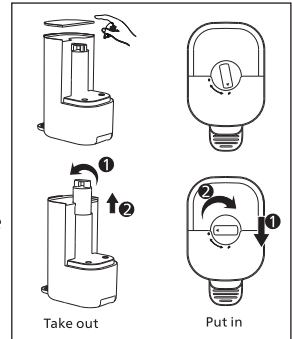

## Reset the filter lifetime

- Long press "Ambient" + "150ml" for 3 seconds to reset the filter cartridge lifetime. There will be 3 beeps. The indicator light changes to blue again, and this means the filter lifetime has been reset successfully.

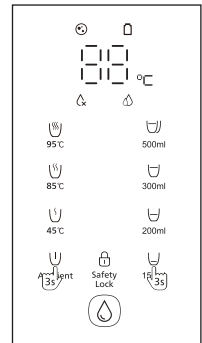

## 9. Error codes

### **E1: Tap water temperature sensor abnormality**

**Solutions:** Check the tap water tank, discard the water if the water temperature exceeds 55°C; put the tap water tank back to the machine. Please contact customer services if the problem cannot be solved.

### **E2: Outlet water temperature sensor abnormality**

**Solutions:** Extract 300ml of ambient water. Please contact customer services if the problem cannot be solved.

### **E4: Heating element temperature sensor abnormality**

**Solutions:** Stop using the dispenser or extract 300ml of ambient water, let the heating element to cool down to normal temperature and then extract hot water. Please contact customer services if the problem cannot be solved.

### **E6: Water filtration abnormality**

**Solutions:** Turn off the power for 1-2 minutes, check whether the filter cartridge is installed properly and then reconnect the power. Please contact customer services if the problem cannot be solved.

### **EU: Display panel malfunction**

**Solutions:** Please contact customer services.

# 10. Troubleshooting

Error	Causes	Solutions
Cannot extract ambient water	The product is not connected with the power supply.	Check if the dispenser is well connected with power supply.
	Button is not pressed properly.	Press the water extraction button again.
Cannot extract hot water	The dispenser is dry-heating.	Extract ambient water for several times, and then extract hot water.
	The water in the filtered water tank is at low level.	Wait for a while till the water filtration indicator stops flashing.
Cannot filter water	Filter cartridge is not installed properly.	Disconnect the dispenser from the power supply. Open the machine's top lid and take out the filter cartridge, then install it properly.
	The water in the tap water tank is at low water level.	Take out the tap water tank and change water.
	The tap water tank is not installed properly.	Check the tap water tank and install it properly.
Strange noise when filtering	The quality of the tap water does not meet the requirement and the filter cartridge is blocked earlier than expected.	Change the filter cartridge and check it again.
Water leakage	The removable drip tray is full.	Empty the removable drip tray.
	The check valve on tap water tank base is blocked or in the wrong position.	Put the check valve back to the original position or contact customer services.
	The sealing valve at the bottom of the tap water tank is blocked.	Remove the blockage.
	Water oozes from the dispenser.	Empty the tap water tank and filtered water tank, power off, then contact customer services.
Odd taste of the water	The new dispenser hasn't been cleaned.	Follow the cleaning procedures for first time use.
	The dispenser has not been used for a long time.	Follow the cleaning procedures for first time use.
	Filter cartridge is not changed as required.	Change the filter cartridge.

Leakage of electricity	Bad grounding.	Three-core plug with reliable grounding must be used.
	The power cord is damaged.	Please contact customer services.
Button/display panel does not respond	Damaged parts.	Please contact customer services.
	The system halts.	Disconnect the dispenser from power supply for 1-2 minutes and then plug it in again.

## 11. Packing list

Dispenser	1x
Removable drip tray	1x
User manual	1x

## 12. Guarantee and support

If you need information or have any questions, please visit [www.philips.com/support](http://www.philips.com/support) or contact the consumer service center in your country/region. If there is no consumer service center in your country/region, please contact your local distributor.

Within two years from the date of purchase, you will receive free warranty service for any damage caused by manufacturing process problems, or any damage to components under normal use conditions confirmed by our maintenance service personnel.

Warranty service excludes frequently replaced consumables, auxiliary equipment, shipping costs and door-to-door service. Please show proof of purchase to service personnel when servicing.

Please keep this user manual for future reference.

## 目錄

1	重要事項	14	7	日常保養	20
2	主要技術參數	15	8	濾芯更換	21
3	結構示意圖	15	9	故障狀態	22
4	操作與顯示界面	16	10	故障排除	23
5	安裝步驟	16	11	裝箱清單	24
6	使用說明	17	12	產品售後服務指南	24

# 1. 重要事項

注意：本項目所有內容均與安全有關，當中解釋了相關風險、危害的程度及可能發生的事故。為了能正確地使用本機器，請用戶務必遵守。

- 誤用本產品可能導致傷害。
- 加熱元件表面在使用後會產生餘熱。
- 本設備僅供家庭和室內使用。
- 請勿將本機浸入任何液體中，以免損壞。
- 請勿使用未經廠方許可的其他配件，若因此造成機器故障，保修將自動終止。
- 請在拆除包裝後檢查機器是否有損壞，並核對配件是否齊全。
- 為了避免窒息的危險，請將塑料袋遠離嬰兒和兒童。
- 本機器進水水質為市政自來水。
- 禁止往原水箱倒入不明液體、不明水質的水或其他異物。
- 請注意輕拿輕放，以免機器跌落造成砸傷。
- 機器應放在兒童及寵物無法觸及的地方。
- 兒童及無行為能力人士請在監護人監督下使用本機器。
- 本機器應放置於室內陰涼乾燥的地方，避免陽光直射，擺放位置不得靠近暖氣設備、電熱產品或其他高溫場所。
- 機器擺放位置不得處於有可能出現可燃性氣體洩漏的場所。
- 切勿用濕手插拔電源插頭，以免引發觸電危險。
- 切勿自行拆卸、改裝機器或在機器上放置重物，以免造成損壞。
- 長期不使用機器，務必斷開電源，排空原水箱和純淨水箱的水。
- 本機器進水溫度要求為5-38°C，如進水溫度超過38°C，會損壞濾芯，使濾芯失效；進水溫度低於5°C時，可能造成凍結，引起機器元件破裂。
- 本機器僅適用於室內安裝與使用，必須使用有可靠接地的三腳插座。
- 初次使用或長期停用後，應裝滿原水箱讓機器開始濾水，在濾水完成後進行一鍵排空，如此反復操作把兩個原水箱份量的水過濾完後即可正常使用。
- 本機器的維修保養需使用指定的部件或配件。
- 嚴禁使用汽油等有機溶劑擦拭本機外殼，確需清潔時，應斷電後用濕抹布輕擦本產品表面。
- 倘若發生故障，應立即拔掉電源插頭，切勿將有缺陷的機器置於工作狀態。
- 隨著產品的升級，說明書上的某些文字或圖案，可能與實際有所不同，請以產品實物為準。
- 如果用戶先取熱水後馬上取常溫水或45°C的水，機器會先出一段殘留熱水，請注意防止燙傷，建議先放常溫水10秒以冷卻加熱體。
- 如果電源線損壞，請停止使用機器，為了避免危險，必須由製造商的專業人員更換。
- 請勿擅自拆解維修本機器或交由非授權的售後服務人員維修，因不當的維修可能造成危險。
- 未按上述注意事項操作所造成的後果，本公司將不承擔任何責任。



## 2. 主要技術參數

產品名稱	飛利浦RO純淨飲水機
產品型號	ADD6901H
額定電壓	220V-240V~
額定總功率	2100W-2400W
製熱水能力	20L/h, $\geq 90^{\circ}\text{C}$ (Max.95度)
濾芯額定總淨水量	2000公升
額定濾水流量	0.13L/分鐘
適用水源	市政自來水
進水壓力	0 - 0.06MPa
適用水溫	5-38 $^{\circ}\text{C}$

## 3. 結構示意圖

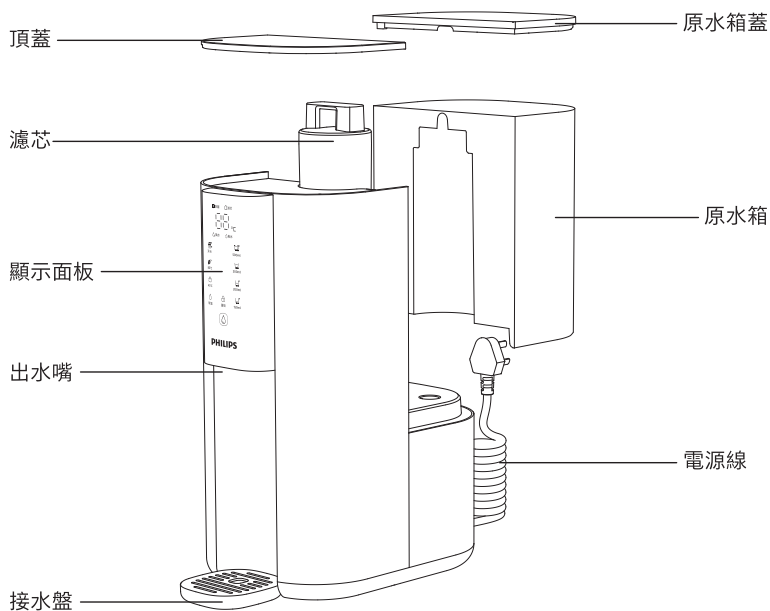

注意：圖示僅供參考。

## 4. 操作與顯示界面

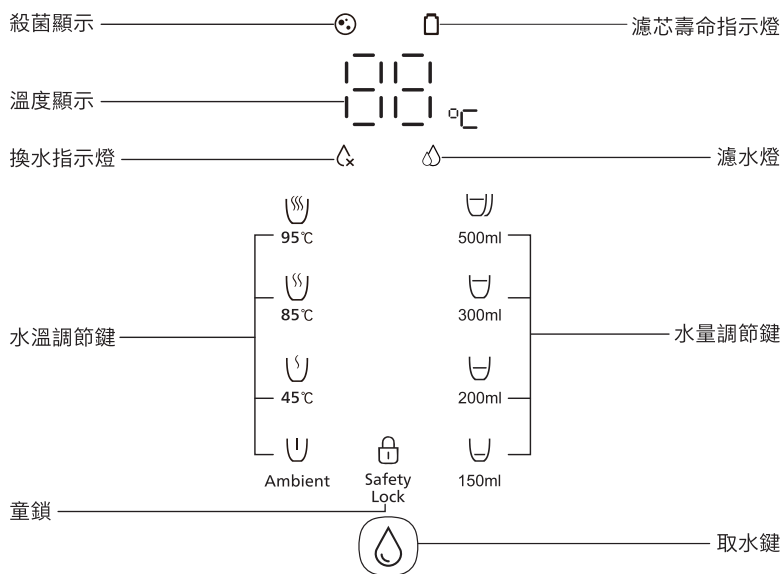



## 5. 安裝步驟

### 安裝飲水機

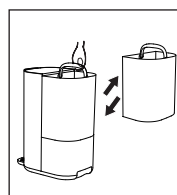
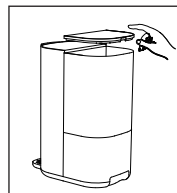
- 請將機器放置在陰涼、通風、穩固的平面上，遠離熱源。
- 打開原水箱蓋，向上提出原水箱，往原水箱注入自來水後裝回機器，並蓋好原水箱蓋。
- 把電源線插頭插入電源插座，機器發出聲音並且點亮顯示面板，表示機器進入工作狀態。



## 首次使用

- 首次使用時，需觀察機器在使用過程中是否有水從機身流出或周邊積水，機器內部是否有異常聲音、焦糊味或煙等，如發現上述情況請斷開電源連接並與售後服務人員聯繫。
- 首次使用時，為了保障最佳過濾性能，應裝滿原水箱讓機器開始濾水，在濾水完成後長按3秒“ 85°C” + “ 300ml”進行一鍵排空並把取出的水倒掉。重覆操作直至2個原水箱的水過濾完成並倒掉。
- 首次使用時，為防止乾燒，機器首次通電取水時，請先取一段常溫水，再取熱水。

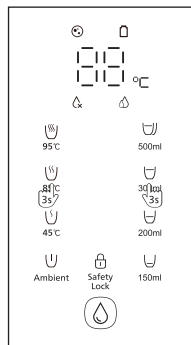

## 6. 使用說明

### 童鎖

- 童鎖啟用及溫度記憶模式：機器會記住上次點擊之預設溫度，取熱水前須先解除童鎖；若10秒無按鍵狀態操作則自動進入童鎖鎖機狀態。長按童鎖10秒，停用童鎖功能及退出溫度記憶模式；取熱水前無須解除童鎖，取熱水後即回復至常溫檔；長按童鎖10秒，再次啟用童鎖功能及進入溫度記憶模式。

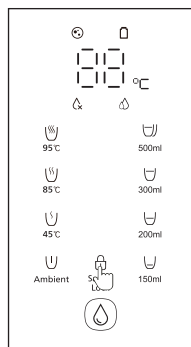

### 沖洗

- 機器通電並蓋上原水箱蓋，在機器濾水前和濾水完成後進入沖洗狀態。
- 強制沖洗：同時長按“ Ambient” + “ Safety Lock”鍵3秒機器進入自動沖洗狀態三分鐘。

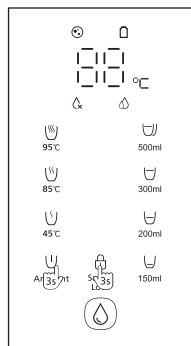

## 濾水

- 當純淨水箱處於低水位狀態時，機器自動進入濾水狀態並持續到濾水完成。在製水狀態時，制水燈常亮顯示，當純淨水箱缺水時，換水指示燈和濾水燈閃爍顯示。

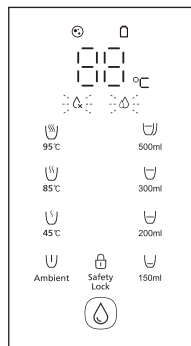

## 水溫調節

- 預設水溫：機器提供“ $\text{U}$  95°C”、“ $\text{U}$  85°C”、“ $\text{U}$  45°C”和“ $\text{U}$  Ambient”4段預設水溫選擇。

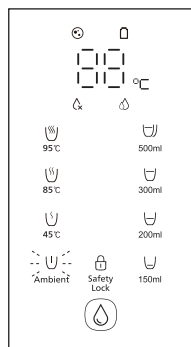

## 水量調節

- 預設水量：機器提供“ $\text{U}$  150ml”、“ $\text{U}$  200ml”、“ $\text{U}$  300ml”和“ $\text{U}$  500ml”4段預設水量選擇。

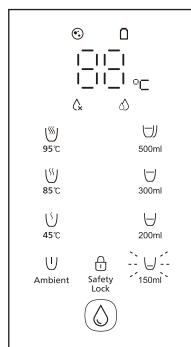

## 取水

- 選擇水溫、水量，顯示屏顯示當前選擇的水溫，點擊童鎖(常溫水自動解鎖)後，點按取水鍵即可取出相應溫度、水量的純淨水，再點按取水鍵或任意鍵都可停止出水。

注意：取熱水時，不可把手伸向出水口下方，以免熱水燙傷。

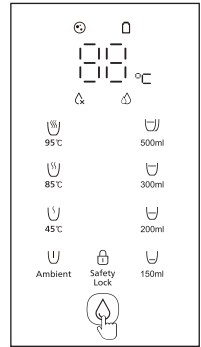

## 換水

當顯示界面中的“換水”圖標閃爍或常亮時，表示原水箱需要換水，以下幾種情況會提示換水：

- 原水箱水位達到或低於最低水位；
- 原水TDS值偏高；
- 原水箱超過48小時未換水。

此時應進行換水操作：打開原水箱蓋，向上提出原水箱並將其中的濃縮水倒掉，再往原水箱注滿水後裝回機器並蓋好。

注意：切勿在未倒掉濃縮水的情況下直接往原水箱中加水。

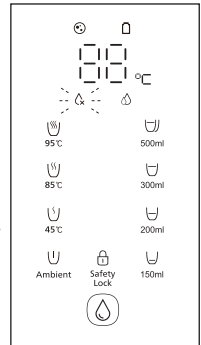

## 冬季模式

- 當原水的水溫低於10°C時，機器可設置冬季模式。
- 長按常溫按鍵3秒，再按取水按鍵，可取25°C 純淨水，僅限單次操作。

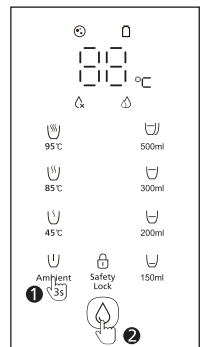

## 休眠模式

- 1分鐘內沒有任何操作，機器進入休眠狀態。
- 機器在休眠狀態中，除童鎖指示燈常亮外其他所有指示燈熄滅。
- 機器在休眠狀態中，觸摸任意鍵，喚醒機器。

## 一鍵排空

- 同時長按85°C 和300ml 按鍵3秒，機器進入一鍵排空狀態，此時機器的出水口開始出水，排空純淨水箱及機器內部的水。

注意：為防止乾燒，一鍵排空操作後，請先取一段常溫水，再取熱水。

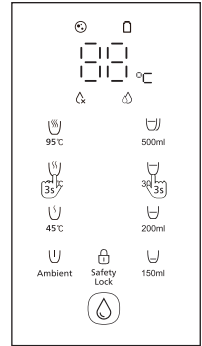

# 7. 日常保養

如果兩天以上沒有使用機器，建議更換原水箱的水並進行兩次一鍵排空操作。

如果計劃長期（超過一周）不使用機器，請先使用一鍵排空排空原水箱中和純淨水箱內的水，斷開電源並將濾芯密封好，放入冰箱保鮮室保存（攝氏2-5度，切勿放進冰格），再次使用時，請按首次使用的步驟清洗。

## 原水箱除垢

- 原水箱需要定期進行除垢清潔，建議每3個月一次，避免原水箱內部嚴重結垢
- 除垢清潔：在原水箱注入半箱水，加入30克檸檬酸，攪拌融化後，浸泡2小時以上（單獨放置，不要放回機器），然後倒掉檸檬酸溶液，用自來水及清潔刷清洗一遍原水箱後，即可正常使用。

\* 檸檬酸及清潔刷需另外購買。

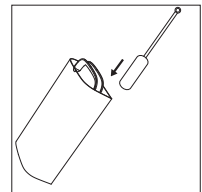

## 8. 濾芯更換



請根據濾芯壽命指示燈或建議更換週期更換濾芯。新的濾芯可從經授權的經銷商處或服務中心購買，其型號為：ADD541

名稱	濾芯
型號	ADD541
建議更換週期	1年
* 僅可使用原裝飛利浦濾芯	

### 濾芯壽命顯示

- 濾芯壽命指示燈顏色代表濾芯剩餘壽命概況：
  - 藍色時，表示濾芯剩餘壽命多於10%；
  - 紅色閃爍時，表示濾芯剩餘壽命小於10%；
  - 紅色常亮時，表示濾芯剩餘壽命少於7天或壽命到期。

### 濾芯更換步驟

- 拔出電源。
- 取出原水箱後再取出機器頂蓋。
- 將需要更換的濾芯逆時針旋轉至開鎖“”位置並提出。
- 將新的濾芯放進濾芯槽並順時針旋入至鎖上“”位置，然後蓋上機器頂蓋並裝回原水箱。
- 恢復機器電源，重置濾芯壽命計算器並按首次使用操作沖洗濾芯。

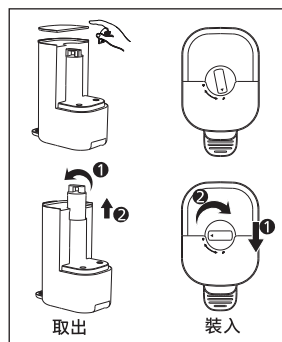

### 重置濾芯壽命計算器

- 恢復機器電源，長按“常溫” + “150ml” 3秒鐘時間（樂音提示3聲）即可重置濾芯壽命計算器，濾芯指示燈恢復藍色即代表重置成功。

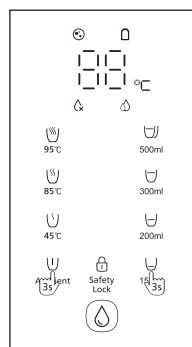

## 9. 故障狀態

### E1: 原水溫度探測器異常

處理方法: 請檢查純水箱水溫是否超過55°C並使用正常水溫, 若無法恢復請聯繫售後處理。

### E2: 出水溫度探測器異常

處理方法: 請取300ml常溫水, 若無法恢復請聯繫售後服務人員處理。

### E4: 加熱體溫度探測器異常

處理方法: 暫停使用或取300ml常溫水, 等加熱體溫度恢復正常後再取熱水, 若無法恢復請聯繫售後服務人員處理。

### E6: 濾水異常

處理方法: 關閉電源1-2分鐘, 檢查濾芯是否安裝妥當, 重新連接電源, 若無法恢復請聯繫售後服務人員處理。

### EU: 顯示面板失靈

處理方法: 請聯繫售後服務人員處理。



# 10. 故障排除

故障現象	故障可能的原因	解決方法
不能取常溫水	機器未通電	檢查電源連接是否正常
	未能按到正確按鍵位置	重新觸摸按鍵進行取水操作
不能取熱水	機器處於“乾燒警報”狀態中	先取用幾次常溫水，再取其他溫度的熱水
	純淨水箱缺水	待純淨水箱有一定水量或水滿時即可正常取熱水
機器不濾水	濾芯未安裝到位	拔出電源，打開機器上蓋，將濾芯拆下後重新安裝到位
	原水箱水位處於低水位狀態	請提出原水箱進行換水
	原水箱未安裝到位	請檢查原水箱是否安裝到位
濾水聲音異常	水質較硬較差，濾芯提前堵塞	更換濾芯後重新觀察
機器漏水	接水盤水滿溢出	請清空接水盤
	原水箱座單向閥被異物卡住或移位	將單向閥調整歸位或聯繫售後服務人員更換單向閥
	原水箱底部密封閥被異物卡住	將異物移除
	機器內部滲漏	請清空原水箱及純淨水箱，並關閉電源，聯繫售後服務人員
水中有異味	使用未沖洗的新機器	按首次使用的步驟清洗機器及濾芯
	機器長時間未使用	按首次使用的步驟清洗機器及濾芯
	濾芯未及時更換	更換濾芯
漏電及機身帶感應電	機器接地不良	必須使用有可靠接地的三孔插座
	電源軟線破損	請聯繫售後服務人員
按鍵/顯示屏無反應	機件損壞	請聯繫售後服務人員
	系統死機	關閉電源1-2分鐘，再重新連接電源

# 11. 裝箱清單

主機	1x
接水盤	1x
使用說明書	1x

# 12. 產品售後服務指南

如果您需要信息或有任何問題，請訪問 [www.philips.com/support](http://www.philips.com/support) 或聯繫您所在國家/地區的消費者服務中心。如果您所在的國家/地區沒有消費者服務中心，請聯繫當地經銷商。自購買之日起兩年內，因製造過程問題造成的任何損壞，或經我們維修服務人員確認的在正常使用狀況下的部件損壞，您將獲得免費保修服務。保修服務不包括經常更換的耗材、輔助設備、運輸費用和上門服務。維修時請向服務人員出示購買憑證。





Register your product and learn more via the website link below:

[www.philips.com/water](http://www.philips.com/water)

Specifications are subject to change without notice

© 2022 AquaShield

All rights reserved.

Philips and the Philips Shield Emblem are registered trademarks of Koninklijke Philips N.V. and are used under license.

This product has been manufactured by and is sold under the responsibility of Hong Kong AquaShield Health Technology Company Limited

and Hong Kong AquaShield Health Technology Company Limited is the warrantor in relation to this product.

Rev A DEC 22

