

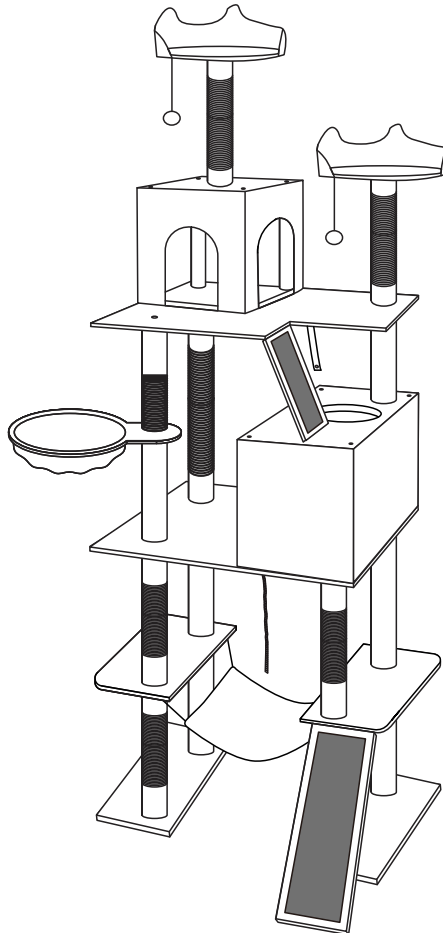

ÁRBOL PARA GATOS 208 cm

ITM. / ART. 1748775

Hecho en China



EN - Please read this instruction manual carefully before attempting to assemble.

FR - Lisez attentivement cette notice avant de commencer le montage.

ES - Por favor lea con atención el manual de instrucciones antes de llevar a cabo el ensamble.

IMPORTANT/IMPORTANT / ATENCIÓN



EN - We recommend more than 1 person to assemble this item.
FR - Il est recommandé d'effectuer le montage à plus d'une personne.
ES - Recomendamos realizar el ensamble con 1 o más personas.



EN - The expected assembly time is **1 h**.
FR - Le temps nécessaire est estimé à **1 h**.
ES - El tiempo aproximado de ensamble es de 1 h



EN - Not intended for use by children.
FR - Produit non destiné à être utilisé par des enfants.
ES - Producto no apto para niños.











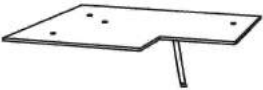

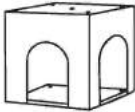

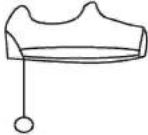
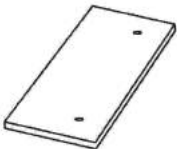

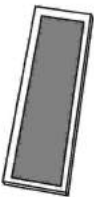



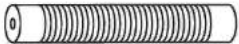

EN - Keep away from fire or other heat sources.
FR - Tenir à distance des flammes et autres sources de chaleur.
ES - Manténgase alejado de las llamas y otras fuentes de calor.







EN - Please follow the instruction manual and place the product on a pad during assembly to keep the unit clean and damage free.

FR - Veuillez suivre les instructions de la notice et placer le produit sur un tapis, une couverture ou un autre support pendant l'assemblage pour éviter de le salir ou de l'endommager.

ES - Sigue por favor las instrucciones del manual y coloca el producto sobre una almohadilla durante el ensamblaje para mantener la unidad limpia y libre de daños.



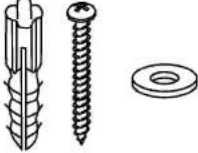

①	②	③
		
x1	x1	x1
④	⑤	⑥
		
x1	x1	x2
⑦	⑧	⑨
	 L	 R
x2	x1	x1
⑩	⑪	⑫
		
x1	x1	x1

<p style="text-align: center;">⑬</p>	<p style="text-align: center;">⑭</p>	<p style="text-align: center;">⑮</p>
<p style="text-align: center;"></p> <p style="text-align: center;">55 cm 21.6 in.</p>	<p style="text-align: center;"></p> <p style="text-align: center;">40 cm 15.7 in.</p>	<p style="text-align: center;"></p> <p style="text-align: center;">40 cm 15.7 in.</p>
<p style="text-align: center;">× 1</p>	<p style="text-align: center;">× 2</p>	<p style="text-align: center;">× 2</p>
<p style="text-align: center;">⑯</p>	<p style="text-align: center;">⑰</p>	<p style="text-align: center;">⑱</p>
<p style="text-align: center;"></p> <p style="text-align: center;">35 cm 13.8 in.</p>	<p style="text-align: center;"></p> <p style="text-align: center;">35 cm 13.8 in.</p>	<p style="text-align: center;"></p> <p style="text-align: center;">35 cm 13.8 in.</p>
<p style="text-align: center;">× 2</p>	<p style="text-align: center;">× 2</p>	<p style="text-align: center;">× 2</p>
<p style="text-align: center;">⑲</p>	<p style="text-align: center;">⑳</p>	<p style="text-align: center;">㉑</p>
<p style="text-align: center;"></p> <p style="text-align: center;">30 cm 11.8 in.</p>	<p style="text-align: center;"></p> <p style="text-align: center;">24.5 cm 9.7 in.</p>	<p style="text-align: center;"></p> <p style="text-align: center;">24.5 cm 9.7 in.</p>
<p style="text-align: center;">× 1</p>	<p style="text-align: center;">× 1</p>	<p style="text-align: center;">× 1</p>
<p style="text-align: center;">㉒</p>	<p style="text-align: center;">㉓</p>	<p style="text-align: center;">㉔</p>
<p style="text-align: center;"></p> <p style="text-align: center;">27 cm 10.6 in.</p>	<p style="text-align: center;"></p> <p style="text-align: center;">22 cm 8.7 in.</p>	<p style="text-align: center;"></p>
<p style="text-align: center;">× 4</p>	<p style="text-align: center;">× 4</p>	<p style="text-align: center;">× 1</p>

<p style="text-align: center;">(A)</p>	<p style="text-align: center;">(B)</p>	<p style="text-align: center;">(C)</p>
		 <p style="text-align: center;">25 mm 0.9 in.</p>
<p style="text-align: center;">X 8 + 1</p>	<p style="text-align: center;">X 26 + 1</p>	<p style="text-align: center;">X 3</p>
<p style="text-align: center;">(D)</p>	<p style="text-align: center;">(E)</p>	<p style="text-align: center;">(F)</p>
 <p style="text-align: center;">16 mm 0.6 in.</p>		
<p style="text-align: center;">X 8 + 1</p>	<p style="text-align: center;">X 4</p>	<p style="text-align: center;">X 1</p>
<p style="text-align: center;">(G)</p>		
		
<p style="text-align: center;">X 1</p>		

Importado por: Importadora Primex S.A. de C.V.
 Blvd. Magno centro No. 4 San Fernando La Herradura
 Huixquilucan, Estado de México, C.P. 52765
 RFC: IPR-930907-S70
 Tel.: (55) 5246-5500
www.costco.com.mx

1

③		x1
④		x1
22		x4
23		x4
Ⓑ		x16

EN - Lightly tighten screws until the unit is fully assembled, then tighten to the point of resistance. Do not over tighten.

FR - Ne serrez que légèrement les vis pendant le montage, une fois le montage complet, serrez-les à fond. Ne forcez pas le vissage trop loin.

ES - Apriete ligeramente los tornillos hasta que la unidad esté completamente montada, luego apriete hasta el punto de resistencia. No apriete en exceso.

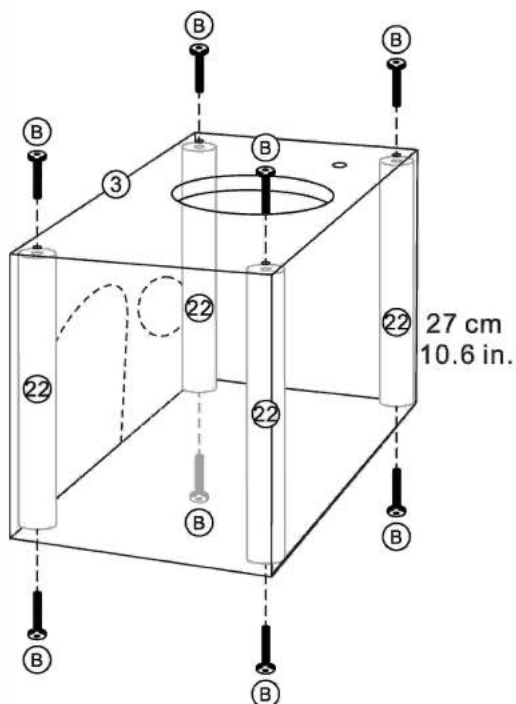
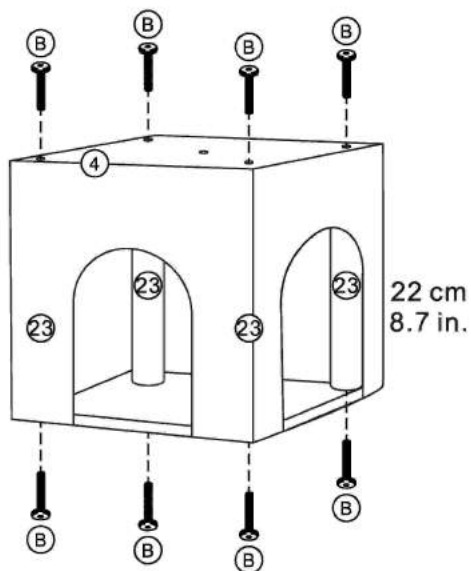



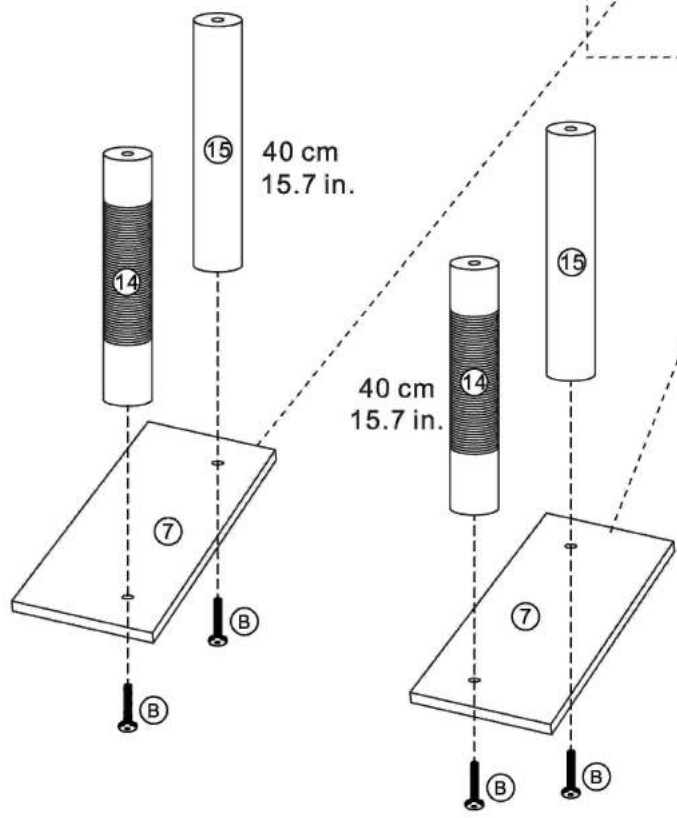
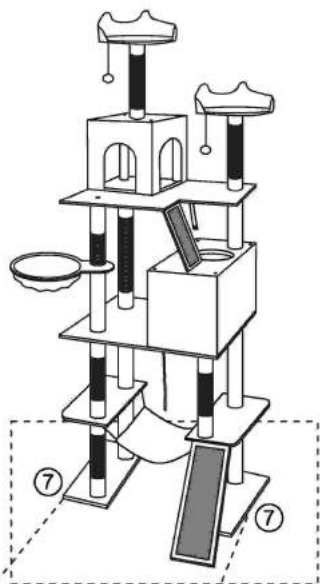

2

⑦		x2
⑭		x2
⑮		x2
Ⓑ		x4





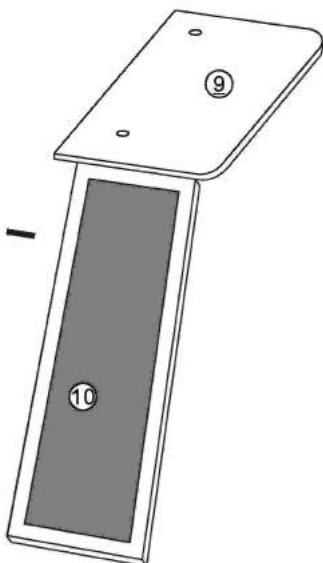
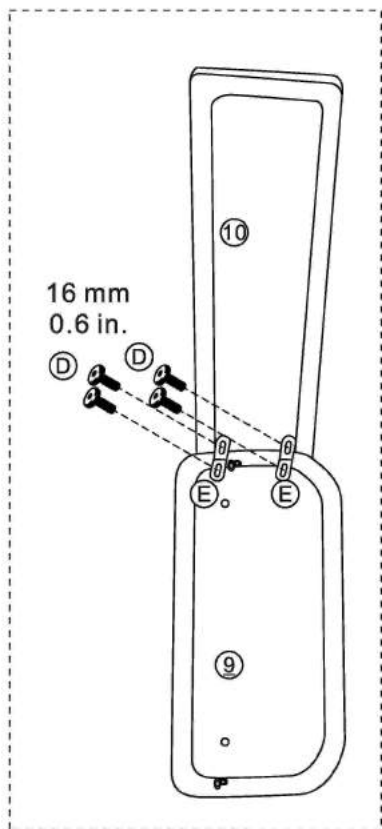
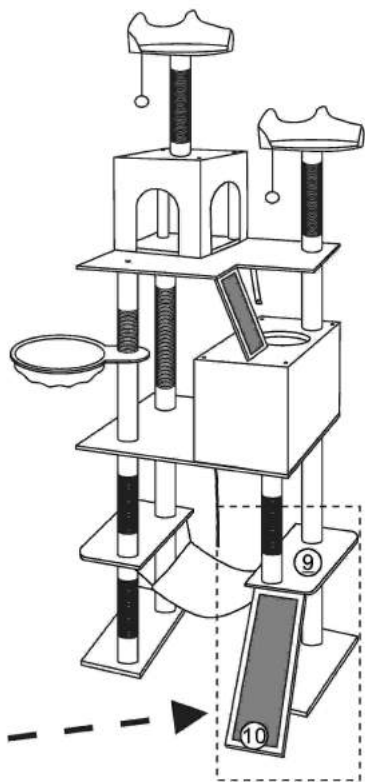

3

⑨		x1
⑩		x1
Ⓓ		x4
Ⓔ		x2





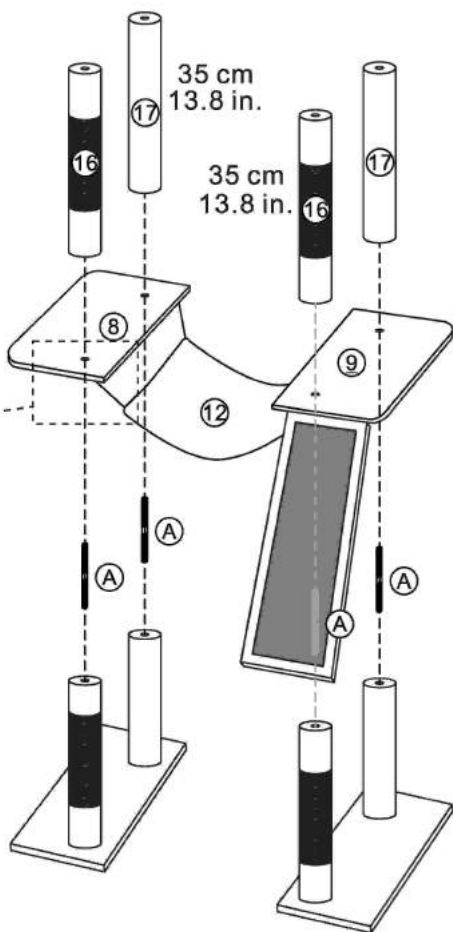
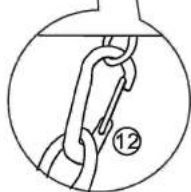
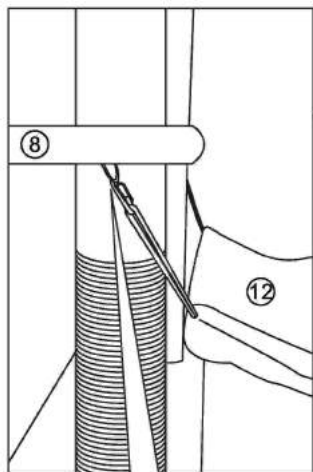

4

⑧		x1
⑫		x1
⑯		x2
⑰		x2
Ⓐ		x4







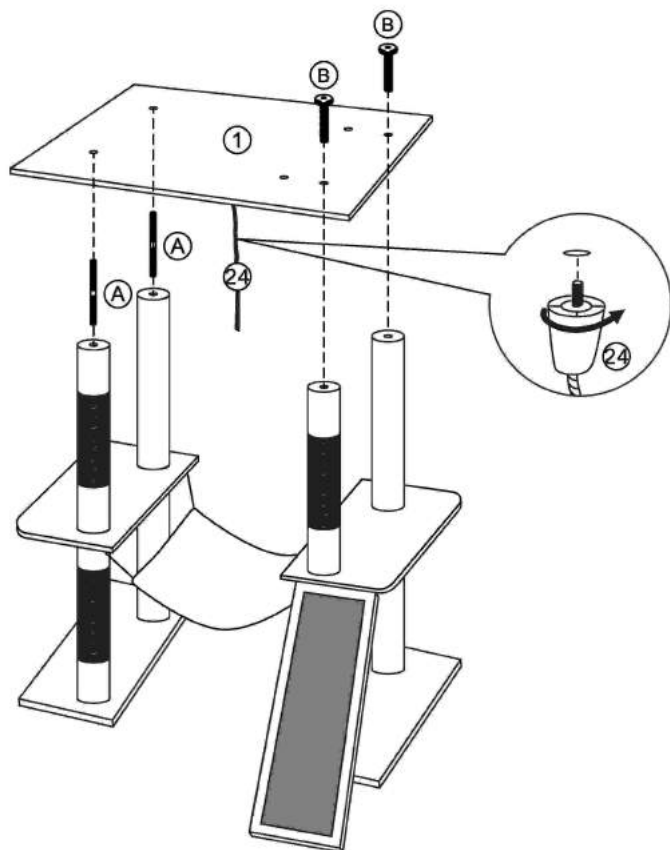
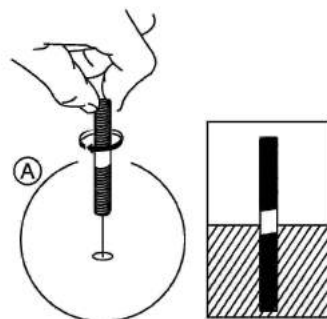



5

①		x1
24		x1
(A)		x2
(B)		x2





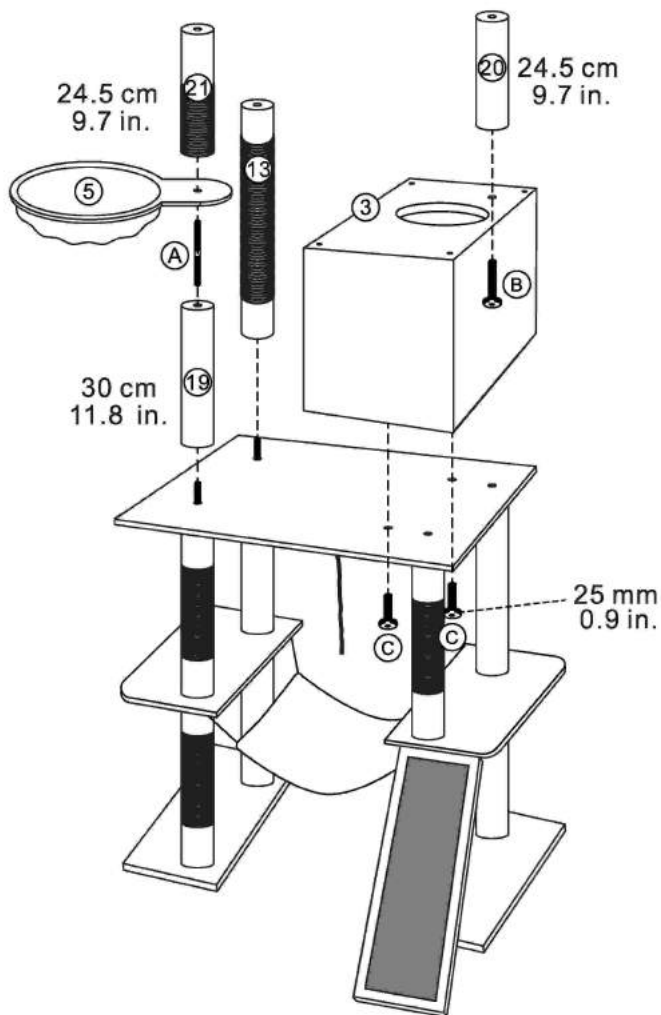
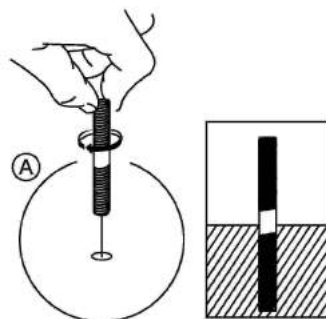

6

⑤		x1
⑬		x1
⑲		x1
⑳		x1
㉑		x1
Ⓐ		x1
Ⓑ		x1
Ⓒ		x2



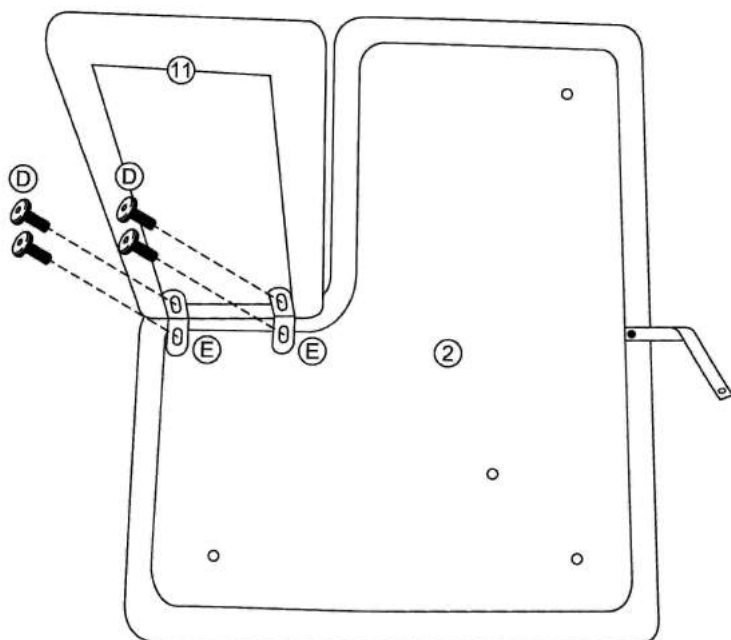

7

②		x1
⑪		x1
ⓓ		x4
ⓔ		x2





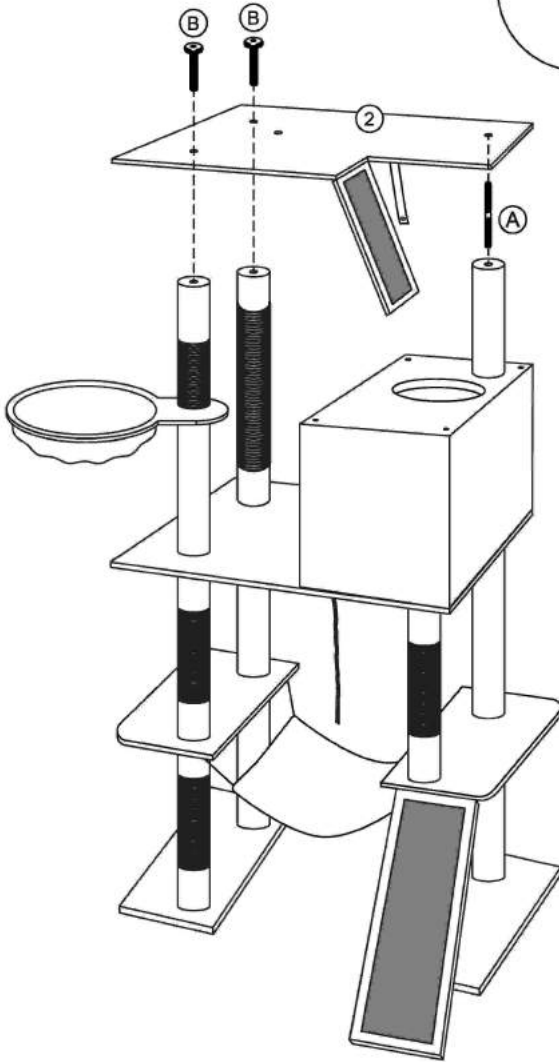
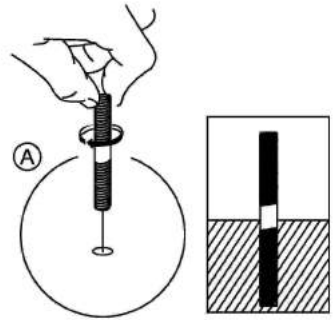

8

(A)	 x1
(B)	 x2



9

⑥		x2
18		x2
B		x1
C		x1

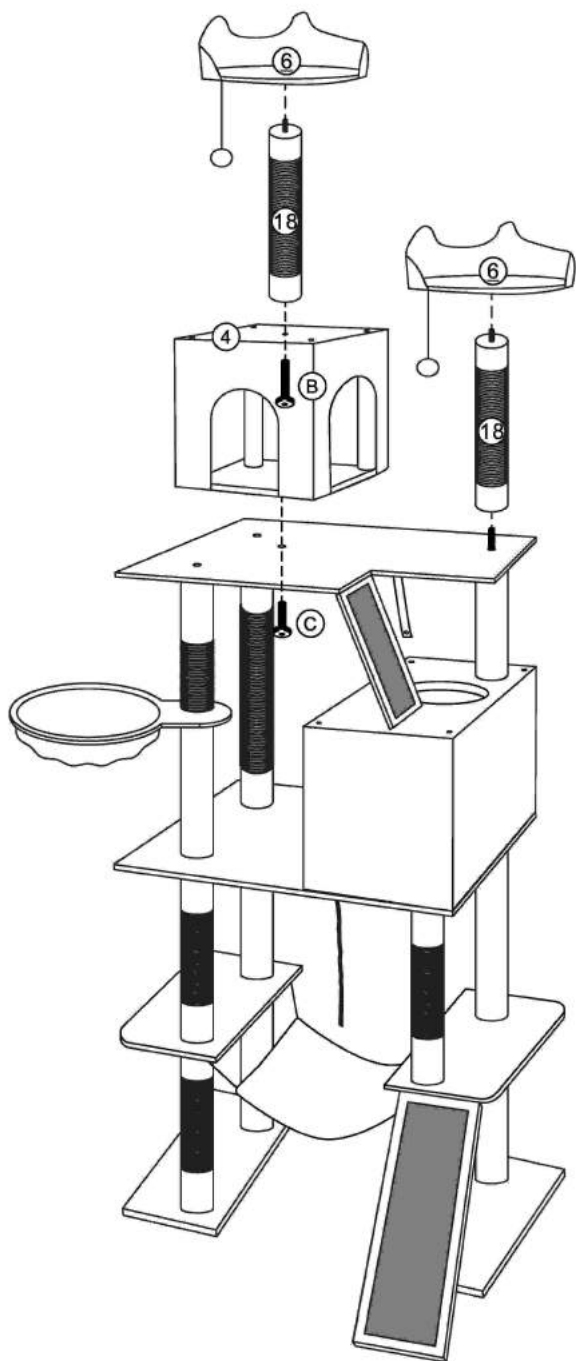

10



EN - Insert anti-tip hardware into wall via pre-installed strap.

FR - Fixez le système anti-basculement au mur à l'aide de la sangle pré-installée.

ES - Inserta el herraje antivuelco en la pared a través de la correa preinstalada.

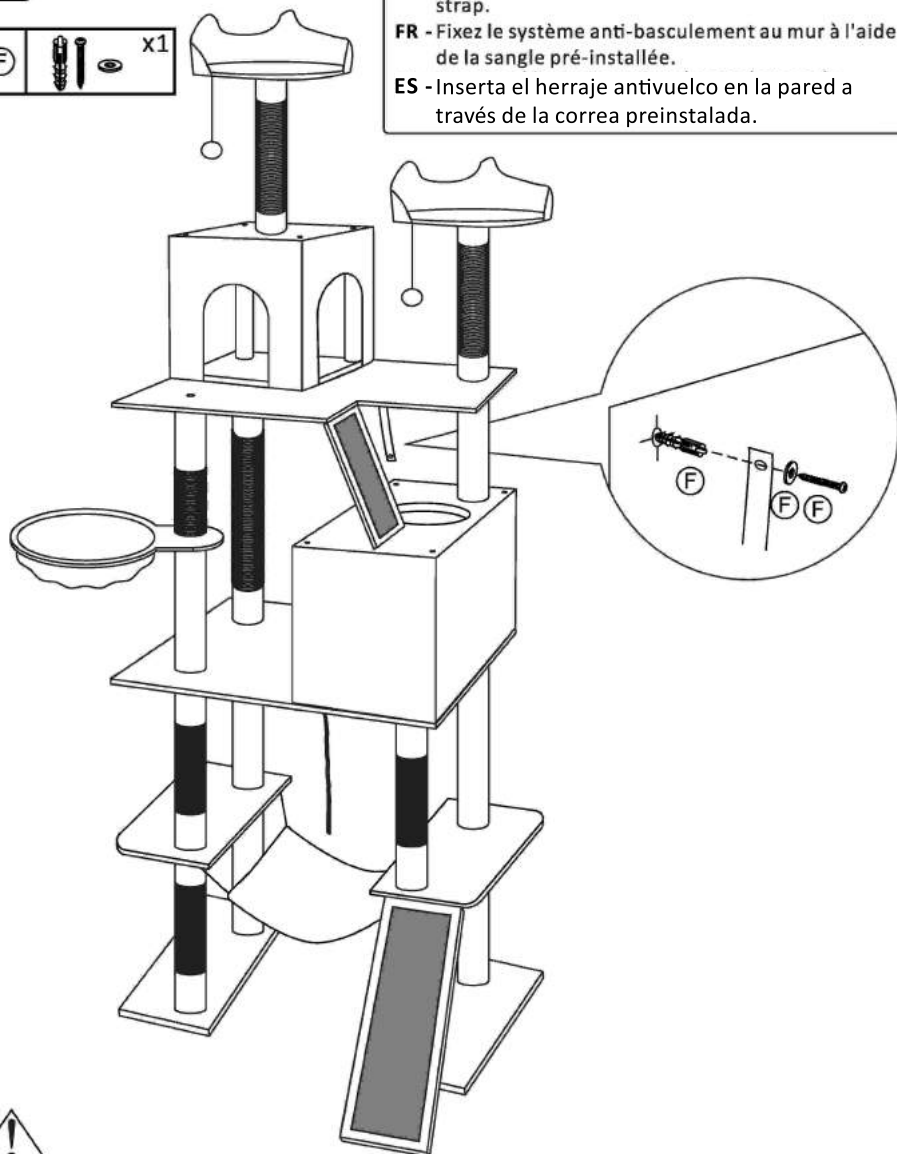

EN - Please remove the bell(s) from the hanging toy balls if your cats tend to eat foreign objects.

FR - Veuillez retirer le(s) grelot(s) des pompons suspendus si vos chats ont tendance à manger les objets étrangers.

ES - Por favor, retira los cascabeles de la(s) bola(s) de peluche colgante(s) si tus gatos tienden a comer cosas extrañas.