

組裝說明

3.3公尺 / 11英呎戶外遮陽傘

ITM. / ART. 1713537, 1768212

內含重要資訊，請保留以供日後參考：請詳閱。

本產品僅適用於戶外營業與居家使用。

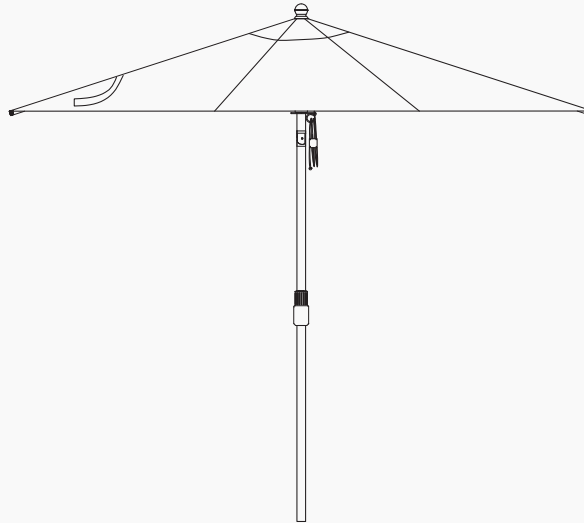

遇到問題、疑難、零件遺失？

在將商品退回零售商之前，可先撥打 1-888-690-9800與我們的客服部門聯絡（來電請於（太平洋時間）上午8:00 - 下午5:00；東部時間（上午11:00 - 下午8:00，週一至週五。提供英語與西班牙語服務）），或是寄送電子郵件至：survice@sunvilla.com。

準備工作

開始組裝本產品之前，確保所有零件都未遺漏。所有的零件使用包裝內容明細以及五金內容明細進行比對。若有任何零件遺失或受損，則請勿嘗試組裝本產品。停止組裝並與我們的客服中心聯絡。在嘗試進行組裝或安裝本產品之前，請閱讀並了解本手冊全文。本產品不應當成玩具或工具。

孩童不應參與本產品的操作、組裝、移除或拆卸作業。

預計組裝時間：10分鐘。組裝需使用的工具：無。



⚠️ 安全事項

本產品的用途在於提供遮陽。切勿在風大的狀況、陣風或是暴風時任其無人看顧、完全展開或是使用。

遮陽傘在不使用以及非使用季節時，最好由傘座內移除。製造商或零售商皆不承擔在強風暴雨時未將遮陽傘由傘座內移除而造成的任何產品，或是其他物品的損失、損壞之責任義務。

遮陽傘零件明細

⚠ 警告： 為避免新的遮陽傘受損，請以外箱或是其他柔軟表面（例如地毯）作為工作面，以免產品在組裝時損壞。

零件編號		內容說明	數量
A		上端傘架與傘面	1
B		下端傘柄	1
C		遮蓋	1

內含重要資訊，請保存以供日後參考：請詳閱

遮陽傘的組裝

步驟1

將遮蓋 (C) 以順時針方向轉動鎖入傘頂。

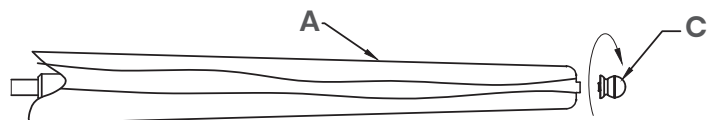

步驟2

將下端傘柄以順時針方向轉動鎖入上端傘架。

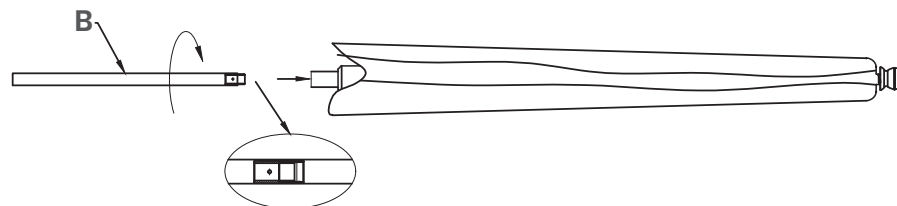

遮陽傘的組裝 (接上頁)

步驟3

將遮陽傘固定於合適的遮陽傘傘座 (本產品未附) 。
打開遮陽傘之前，稍微地拉開傘骨讓它展開來。
將繩子拉下張開遮陽傘。

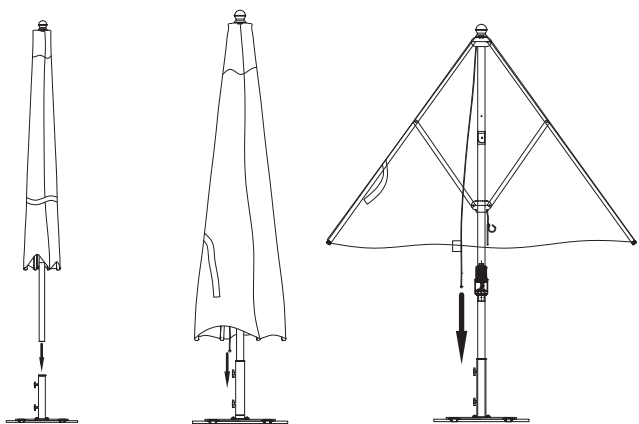

步驟4

遮陽傘完全的展開後將插鎖插入孔內。
以繩子在插鎖處纏繞並繫緊。

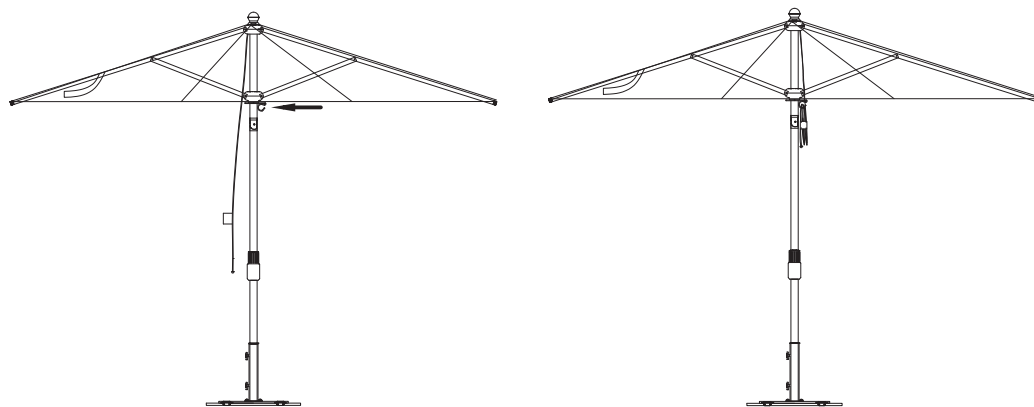

遮陽傘的組裝 (接上頁)

步驟5

順時針轉動套管可使遮陽傘的傘面傾斜，逆時針轉動可將傘面打直。註：遮陽傘傾斜至最大30度角時會停止傾斜。請勿繼續轉動套管迫使其超過此停止點。



步驟6

要將遮陽傘恢復至閉合的位置時，將插鎖拔出。鬆開繩子將遮陽傘收折起來。不使用時，以所附的束帶把遮陽傘固定好。

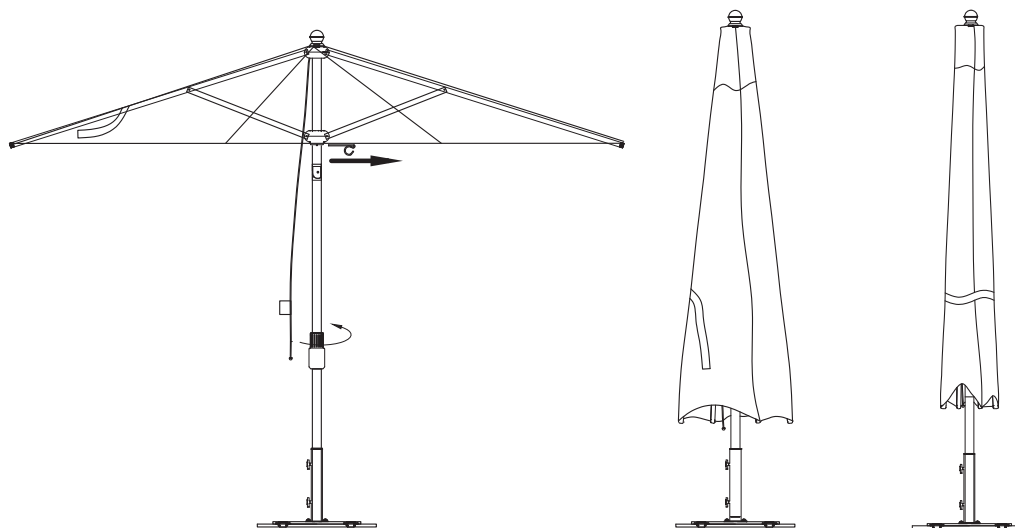

維護與保養

遮陽傘

讓濕的傘面以展開的位置在陽光下曬乾。

不使用的季節應收納在乾燥處。

遮陽傘應遠離火或熱源。

布料

Sunbrella® 布料是以100%原抽色紗布料製成，足以承受戶外使用之高要求。

為使布料維持其最佳狀態，我們建議一旦看到污物或污漬便應清潔布料。而針對布料的日常保養，我們建議應在每年的春季進行清理。

將散落的灰塵污物刷掉。

噴灑溫和無刺激性的肥皂水清潔溶劑。

以柔軟的鬃毛刷進行清洗。

讓清洗溶劑浸濕布料。

徹底地沖洗直到無肥皂殘留。

自然風乾。

為維持布料的使用壽命，不使用時請收納於室內。

保固

戶外家具 兩年有限保固方案

依據本有限產品保固，自購買日後的兩（2）年期間，製造商會針對瑕疵零組件提供維修或更換的保固服務。本保固為製造商與原始購買者之間的保固條款，並只有隨同原始購買者附上顯示原始購買日與購買地點的銷貨收據始具效力。依據本保固所進行的零組件更換，會恢復至原始購買日期作為未來的保固效期。

製造商或其授權業者會依據其調查結果，同意或拒絕保固要求。本保固僅適用於一般家用，而不適於營業用。製造商可依需要置換同等價值及效用的材料、零組件以及子組件。本保固僅限為產品進行維修或更換（全然依製造商之判定）。退回以進行保固服務時，僅限單一受損的零組件。

本有限產品保固之範圍僅限製造上的瑕疵而未包含正常損耗、因自然災害（例如，但不限於冰凍或疾風）造成的損壞、濫用或誤用，包括因防曬油或其他化學品造成的化學損害、曝露在極熱或極冷的環境、磨損或過重所造成的損壞。本產品僅適合在標準安裝下進行使用。本產品若未按其設定用途使用，將會失其保固效力。製造商拒絕承擔因任何部分的安裝，以及由任一零組件的瑕疵零件所造成的任何不便之責任義務。

部分品項並未涵蓋於本保固範圍。這些包含但並不限於以下所列：

1. 零組件遭到濫用，包括模擬故障的濫用行為。
2. 由零售商、出貨人或是安裝人員造成的毀損（諸如刮痕、凹陷、裂縫、碎屑等）。
3. 僅出現正常磨損但功能如同新品的所有零件，包括碎屑、刮痕或是伸縮的材質與邊縫。
4. 裂縫、穿孔、刮痕或是因任何不適當的安裝或使用所造成的任何損壞。
5. 未正確組裝或是暴露於水以及 / 或冰點下的溫度而導致傘骨 / 焊接處受損，並未涵蓋在保固範圍內。一般傘骨生鏽並未涵蓋在本保固範圍。
6. 布料 / 坐墊 / 束帶 / 柳編因曝露在惡劣氣候、化學品、油、液體或其他任何因素而導致褪色以及 / 或變色，並未涵蓋在本保固範圍。
7. 遮陽傘底座在任何情況下都不會是本保固之保障項目。
8. 依「原貨樣」或是展示品出售的品項。

提出保固要求時，應撥打下列免付費電話。請將一份有效的原始銷貨收據影本附上問題的簡短敘述說明。也請提供您的電子郵件地址，以及白天的聯絡電話或是手機號碼。所有物件會收取實際的運費加上15美元的處理費用。維修或更換會依製造商的選擇進行作業。營業稅或使用稅，外加運送及處理費為消費者應負擔之費用。

此為完整的唯一明示有限責任。製造商不會針對任何其他保固（包含那些零售經銷商的擔保），不論是明示或默示，予以承諾或是承擔責任義務。本專屬補償辦法僅限依據本保固陳述之條款與條件，而對視為瑕疵的所有產品或零組件予以維修或更換之相關補償。本產品製造商亦或其代理商在任何狀況下，即使已被告知此類損失發生的可能，皆無須承擔因使用本產品或由於任何違反本保固或是疏忽所造成的附帶、間接、特殊或是關連性損失。除法律所作的其他規定外，並無本文所述的保固之外的其他明示或默示保固，而其他所有的保固，包含所有商品性能或是符合特定用途之默示保證皆明確地拒絕承認。

3.3 m / 11 ft Market Umbrella

ITM. / ART. 1713537, 1768212

**IMPORTANT, RETAIN FOR FUTURE REFERENCE: READ CAREFULLY.
THIS ITEM IS INTENDED FOR OUTDOOR COMMERCIAL AND DOMESTIC USE ONLY.**

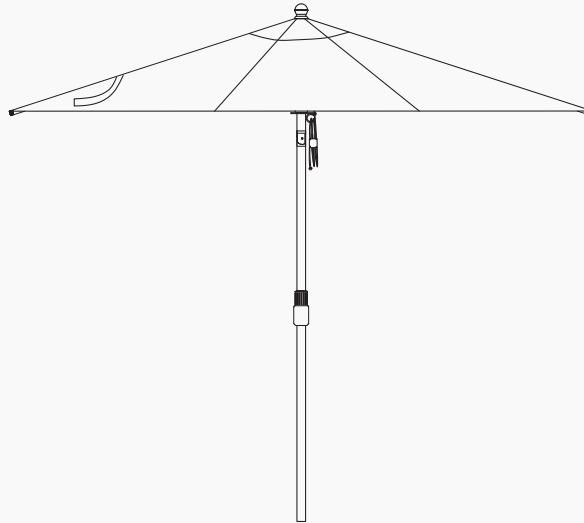

Questions, problems, missing parts?

Before returning to your retailer, call our customer service department at 1-888-690-9800 (8:00 a.m. – 5:00 p.m. PT / 11:00 a.m. – 8:00 p.m. ET, Monday – Friday. English and Spanish) or email us at service@sunvilla.com.

Preparation

Before beginning to assemble this product, make sure all parts are present. Compare parts with package contents list and hardware contents list. If any parts are missing or damaged, do not attempt to assemble this product. Stop and call our customer service center.

Please read and understand this entire manual before attempting to assemble or install the product. It should not be used as a toy or tool.

Children should not engage in the operation, assembly, removal, or disassembly of the product.



Estimated Assembly Time: 10 minutes. Tools Required for Assembly: None.

⚠ Safety Information

The purpose of the umbrella is to provide shade from the sun. Never leave unattended, fully opened, or use in windy conditions, gusts or storms. It is best to remove the umbrella from the base and store when not in use and also in the off season. The manufacturer or retailer is not liable for any loss, damage to the product, or other items due to the failure of not removing the umbrella from an umbrella base during windy-stormy conditions.

Umbrella Parts List

⚠ WARNING: To avoid damage to your new umbrella, please use either the carton or another soft surface such as carpet as a working surface to prevent product damage during assembly.

PART NO.		DESCRIPTION	QTY
A		Upper Frame with Canopy	1
B		Bottom Pole	1
C		Cap	1

IMPORTANT, RETAIN FOR FUTURE REFERENCE: READ CAREFULLY

Umbrella Assembly

Step 1

Screw the Cap (C) into the top of the umbrella by rotating it clockwise.

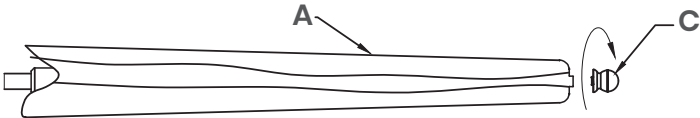

Step 2

Screw Bottom Pole (B) into the upper frame by rotating it clockwise

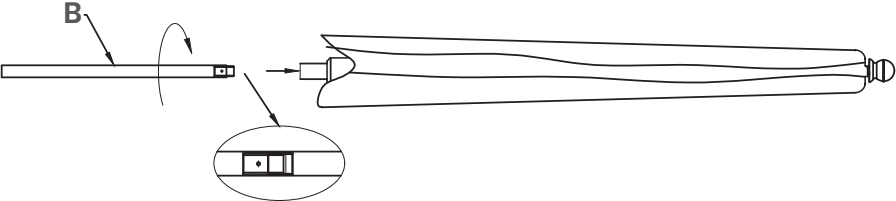

Umbrella Assembly (cont.)

Step 3

Secure the umbrella into an appropriate umbrella base (not included).

Before opening, gently pull apart and separate the umbrella ribs.

Pull the rope down to open the umbrella.

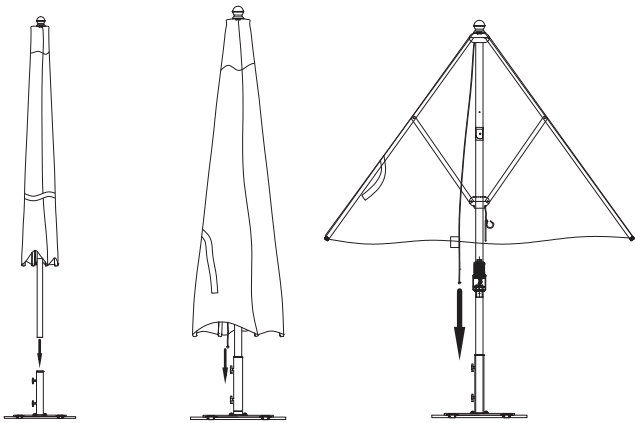

Step 4

Insert the pin into the hole when the umbrella is fully open. Wrap the rope around the pin and tie it.

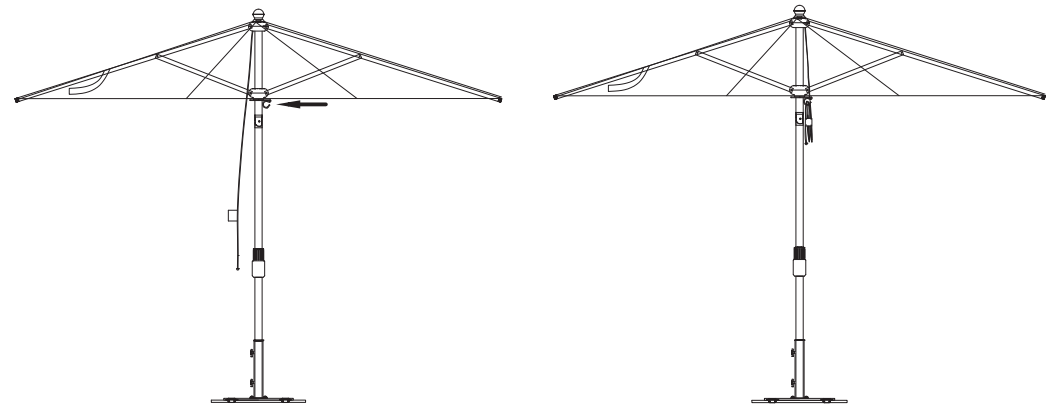

Umbrella Assembly (cont.)

Step 5

Turn the collar either clockwise to tilt the umbrella or turn it counterclockwise to straighten the umbrella.
Note: The umbrella will stop tilting at the maximum tilt of 30 degrees. Do not continue past this stopping point.



Step 6

To return the umbrella to the closed position, pull out the pin. Loosen the rope to close the umbrella. Use the attached ties to secure your umbrella when not in use.

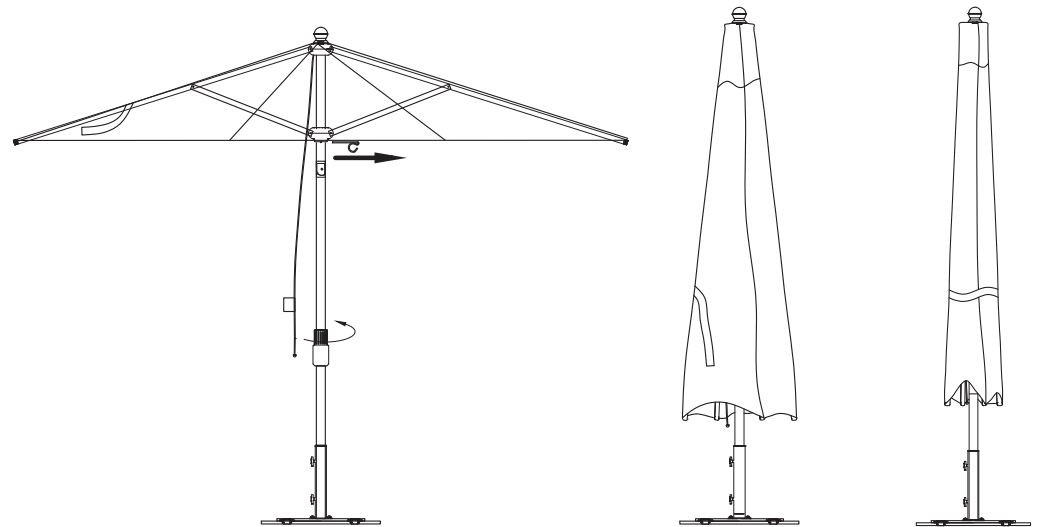

Care and Maintenance

Umbrella

Allow a wet canopy to dry in the open position in the sunlight.
Store in a dry place during the off season.
Keep the umbrella away from fire or heat sources.

Fabric

Sunbrella® fabrics are made of 100% solution-dyed acrylic fibers which are capable of withstanding the high demands of outdoors use. To keep your fabric looking its best, we suggest cleaning the fabric at the first signs of dirt or stains. For routine maintenance of your fabrics, we recommend cleaning each spring season.

Brush off loose dirt.
Spray on a cleaning solution of water and mild soap.
Use a soft bristle brush to clean.
Allow cleaning solution to soak into the fabric.
Rinse thoroughly until all soap residue is removed.
Air dry.
To maintain the life of the fabric, store indoors when not in use.

Warranty

Outdoor Furniture

2-YEAR LIMITED WARRANTY

For a period of two (2) years after date of purchase, the Manufacturer will either repair or replace defective components in accordance with this Limited Warranty. This warranty is between the Manufacturer and the original purchaser and is valid only when accompanied by the original purchaser's sales receipt showing original date of purchase and location of purchase. Replacements under this warranty revert back to the date of original purchase for future warranty.

The manufacturer or its authorized dealer can accept or reject warranty claims based on its findings. This warranty applies in normal residential use only and is not intended for commercial use. The Manufacturer can make substitutions as required of materials, components, and subcomponents of comparable value and utility. This warranty is limited to product repair or replacement (to be determined solely by the manufacturer). Warranty return is limited to only the single affected component.

This limited warranty covers only manufacturing defects and does not cover normal wear and tear, damage due to acts of nature (such as, but not limited to freezing or high winds), abuse or misuse, including chemical damage from suntan oil or other chemicals, exposure to extreme heat or cold, abrasion or excessive weight. This product is intended to be used in standard installations only. This warranty is void if the product is not used for its intended purpose. The Manufacturer disclaims liability for any aspect of installation and any inconvenience caused by a defective part of a component.

Certain items are not covered by this warranty. These include, but are not limited to the following:

1. Components subjected to abuse, including abuse intended to simulate failure.
2. Damages caused by retailer, shipper or installation crew (such as scratches, dents, tears, chips, etc.).
3. Any part which merely exhibits normal wear yet functions essentially as new, including chips, scratches or stretching of materials and stitching.
4. Tears, punctures, scratches or any damage caused by improper installation or use.

5. Damage to frames/welds resulting from improper assembly or exposure to water and/or sub-freezing temperatures is not covered. General frame rusting is not covered.

6. Fading and/or discoloration of fabrics/cushions/straps/wicker resulting from exposure to the elements, chemicals, oils, fluids or any other cause are not covered.

7. Umbrella bases are not covered under any circumstances.

8. Items sold "as is" or floor models.

To make a claim, call the toll-free number below. Please have available a copy of the original sales receipt along with a brief description of the problem. Please also provide your email address and daytime telephone or cell phone number. All items may be charged actual freight costs plus \$15 for handling. Repairs or replacement will be made at the Manufacturer's option. Sales and use taxes, plus shipping and handling charges are the responsibility of the consumer.

THIS IS THE ENTIRE EXCLUSIVE EXPRESS LIMITED LIABILITY. THE MANUFACTURER NEITHER MAKES NOR IS RESPONSIBLE FOR ANY OTHER WARRANTIES, EITHER EXPRESS OR IMPLIED, INCLUDING THOSE OF RETAILING DEALERS. THIS EXCLUSIVE REMEDY IS LIMITED TO RECEIPT OF A CREDIT IN CONNECTION WITH THE REPAIR OR REPLACEMENT OF ANY PRODUCT OR COMPONENT DEEMED TO BE DEFECTIVE UNDER THE TERMS AND CONDITIONS AS STATED IN THIS WARRANTY. NEITHER THE PRODUCT MANUFACTURER NOR ITS AGENTS SHALL BE LIABLE IN ANY CASE FOR INCIDENTAL, INDIRECT, SPECIAL, OR CONSEQUENTIAL DAMAGES RESULTING FROM THE USE OF THIS PRODUCT OR ARISING OUT OF ANY BREACH OF THIS WARRANTY OR NEGLIGENCE EVEN IF IT HAS BEEN ADVISED OF THE POSSIBILITY OF SUCH DAMAGES. EXCEPT AS OTHERWISE MAY BE REQUIRED BY LAW, THERE ARE NO OTHER EXPRESS OR IMPLIED WARRANTIES OTHER THAN THE WARRANTY DESCRIBED HEREIN, AND ALL OTHER WARRANTIES, INCLUDING ANY IMPLIED WARRANTY OF MERCHANTABILITY OR FITNESS FOR A PARTICULAR PURPOSE ARE EXPRESSLY DISCLAIMED.

SUNVILLA

Distributed by:
Costco Wholesale
Corporation P.O. Box 34535
Seattle, WA 98124-1535
USA
1-800-774-2678
www.costco.com

Costco Wholesale Canada Ltd.*
415 W. Hunt Club Road
Ottawa, Ontario
K2E 1C5, Canada
1-800-463-3783
www.costco.ca
* faisant affaire au Québec sous
le nom les Entrepôts Costco

Importado por:
Importadora Primex S.A. de C.V.
Blvd. Magnocentro No. 4
San Fernando La Herradura
Huixquilucan, Estado de México
C.P. 52765
RFC: IPR-930907-S70
(55)-5246-5500
www.costco.com.mx

Costco Wholesale Australia Pty Ltd
17-21 Parramatta Road
Lidcombe NSW 2141
Australia
www.costco.com.au

Costco Wholesale UK Ltd /
Costco Online UK Ltd
Hartspring Lane
Watford, Herts
WD25 8JS
United Kingdom
01923 213113
www.costco.co.uk

Costco Wholesale Spain S.L.U.
Polígono Empresarial Los Gavilanes
C/ Agustín de Betancourt, 17
28906 Getafe (Madrid) España
NIF: B86509460
900 111 155
www.costco.es

Costco Wholesale Iceland ehf.
Kauptún 3-7, 210 Gardabaer
Iceland
www.costco.is

Costco France
1 avenue de Bréhat
91140 Villebon-sur-Yvette
France
01 80 45 01 10
www.costco.fr

Costco Wholesale Japan Ltd.
2 Kakuchi, 2 Gaiku, Kaneda-Nishi
361 Urigura, Kisarazu shi
Chiba, 292-0007 Japan
0570-200-800
www.costco.co.jp

Costco Wholesale Korea, Ltd.
40, Iljik-ro
Gwangmyeong-si
Gyeonggi-do, 14347, Korea
1899-9900
www.costco.co.kr

Costco Wholesale New Zealand Limited
2 Gunton Drive
Westgate
Auckland 0814
New Zealand
www.costco.co.nz

Costco (China) Investment Co., Ltd.
Room 01 Mezzanine
No. 5178, Kang Xin Highway
Pudong New District
Shanghai
China 201315
+86-21-6257-7065

Costco Wholesale Sweden AB
Box 614
114 11 Stockholm
Sweden
www.costco.se

MADE IN CHINA
FABRIQUÉ EN CHINE
HECHO EN CHINA